



# Georgia Standards of Excellence Frameworks

## Mathematics

GSE Grade 6

Unit 5: Area and Volume



Richard Woods, Georgia's School Superintendent  
"Educating Georgia's Future"

## Unit 5 **Area and Volume**

### TABLE OF CONTENTS

OVERVIEW .....	3
STANDARDS FOR MATHEMATICAL PRACTICE .....	4
STANDARDS FOR MATHEMATICAL CONTENT .....	5
BIG IDEAS.....	5
ESSENTIAL QUESTIONS.....	5
CONCEPTS & SKILLS TO MAINTAIN .....	6
<b>*FLUENCY</b> .....	6
STRATEGIES FOR TEACHING AND LEARNING .....	7
MISCONCEPTIONS .....	8
SELECTED TERMS AND SYMBOLS .....	9
INSTRUCTIONAL RESOURCES/TOOLS .....	12
FORMATIVE ASSESSMENT LESSONS (FAL) .....	12
SPOTLIGHT TASKS .....	13
3-ACT TASKS .....	14
<b>Tasks</b> .....	14
• <b>**Who Put the Tang in Tangram?</b> .....	16
• <b>**Rectangle Wraparound</b> .....	24
• Finding Areas of Polygons (Spotlight Task).....	31
• What’s My Area? .....	36
• <b>**King Arthur’s New Table</b> .....	40
• Area of Composite Figures (FAL) .....	47
• <b>**Finding Surface Area</b> .....	48
• <b>**How Many Ways?</b> .....	52
• Banana Bread .....	59
• <b>**Volume and Cubes</b> .....	62
• Packing Our Goods (Spotlight Task).....	71
• Painting the Barn (Spotlight Task).....	77
• Designing Candy Cartons (FAL) .....	84
• Candle Box (Short Cycle Task) .....	85
• Smoothie Box (Short Cycle Task).....	86
• Boxing Bracelets .....	87
• The Filing Cabinet (Spotlight Task).....	94
• Culminating Task: STEM Fish Tank Foam Packaging Design.....	99
<b>*Unit Web Links</b> .....	107

**\*Revised standards, new tasks, and other new resources indicated in bold red font.**

\*\* Existing task modified in the July 2015 edition

## **OVERVIEW**

In this unit students will:

- Find areas of right, equilateral, isosceles, and scalene triangles, and special quadrilaterals.
- Find areas of composite figures and polygons by composing into rectangles and decomposing into triangles and other shapes.
- Solve real-world and mathematical problems involving area.
- Decipher and draw views of rectangular and triangular prisms from a variety of perspectives.
- Recognize and construct nets for rectangular and triangular prisms.
- Find the surface area of rectangular and triangular prisms by using manipulatives and by constructing nets.
- Solve real-world problems that require determining the surface area of rectangular and triangular prisms.
- Measure and compute volume with fractional edge lengths (like  $\frac{1}{2}$  of a unit) using cubic units of measure.
- Find the volumes of right rectangular prisms by substituting given values for their dimensions into the correct formulas.
- Make the connection that finding the volume given the *length* ( $l$ )  $\times$  *width* ( $w$ ) is the same as the *base* ( $B$ ).
- Solve real-world problems that require determining the volume of right rectangular prisms.

Although the units in this instructional framework emphasize key standards and big ideas at specific times of the year, routine topics such as estimation, mental computation, and basic computation facts should be addressed on an ongoing basis. Ideas related to the eight practice standards should be addressed constantly as well. A variety of resources should be utilized to supplement this unit. This unit provides much needed content information, but excellent learning activities as well. The tasks in this unit illustrate the types of learning activities that should be utilized from a variety of sources.

## STANDARDS ADDRESSED IN THIS UNIT

### STANDARDS FOR MATHEMATICAL PRACTICE

**1. Make sense of problems and persevere in solving them.** Given a rectangular prisms, rectangular pyramids, triangular prisms, and triangular prisms students will find surface area using the net. Students will solve problems by finding the volume of rectangular prisms with fractional edges. Students will decompose and compose polygons to find the area.

**2. Reason abstractly and quantitatively** – Students will use their understanding of the value of fractions in solving with area. Students will be able to see and justify the reasoning for decomposing and composing of an irregular polygon/nets using area of triangles and quadrilaterals to solve for surface area. Students will use the relationships between two-dimensional and three-dimensional shapes to understand surface area.

**3. Construct viable arguments and critique the reasoning of others.** Students will justify how they found surface area of rectangular and triangular prisms, area of irregular polygons, and volume of rectangular prisms with fractal edges by packing it with unit cubes. Students will justify why finding the volume of a rectangular prisms by multiplying the length by the width by the height is the same as multiply the area of the base by the height. Students will review solutions and justify (verbally and written) why the solutions are reasonable.

**4. Model with mathematics.** Use hands on/virtual manipulatives (prisms, pyramids and folding nets) using every day two-dimensional and three-dimensional shapes. Students will draw irregular polygons and decompose into triangles and special quadrilaterals.

**5. Use appropriate tools strategically.** Students will use a ruler, graph paper two-dimensional and three-dimensional shapes to solve for area, volume and surface area. In addition, students will determine appropriate area formulas to use for given situations.

**6. Attend to precision.** Students will use appropriate measurement units (square units and cubic units) and correct terminology to justify reasonable solutions.

**7. Look for and make use of structure.** Students will understand the relationship between the structure of a three-dimensional shape and its volume formula. Students also decompose two-dimensional figures to find areas.

**8. Look for and express regularity in repeated reasoning.** Students will explain why formula or process is used to solve given problems. Students use properties of figures and properties of operations to connect formulas to surface area and volume.

## **STANDARDS FOR MATHEMATICAL CONTENT**

**Solve real-world and mathematical problems involving area, surface area, and volume.**

**MGSE6.G.1 Find area of right triangles, other triangles, quadrilaterals, and polygons by composing into rectangles or decomposing into triangles and other shapes; apply these techniques in the context of solving real-world and mathematical problems.**

**MGSE6.G.2 Find the volume of a right rectangular prism with fractional edge lengths by packing it with unit cubes of the appropriate unit fraction edge lengths ( $\frac{1}{2}$  u), and show that the volume is the same as would be found by multiplying the edge lengths of the prism. Apply the formulas  $V = (\text{length}) \times (\text{width}) \times (\text{height})$  and  $V = (\text{area of base}) \times (\text{height})$  to find volumes of right rectangular prisms with fractional edge lengths in the context of solving real-world and mathematical problems.**

**MGSE6.G.4** Represent three-dimensional figures using nets made up of rectangles and triangles, and use the nets to find the surface area of these figures. Apply these techniques in the context of solving real-world and mathematical problems.

### **BIG IDEAS**

- The area of irregular and regular polygons can be found by decomposing the polygon into rectangles and triangles.
- Manipulatives and the construction of nets may be used in computing the surface area of rectangular and triangular prisms, and volume of right rectangular prisms.
- Formulas may be used to compute the areas of polygons and volumes of right rectangular prisms.
- Appropriate units of measure should be used when computing the area (square units) of polygons, surface area (square units) and volume of prisms (cubic units).
- Views of rectangular and triangular prisms may be interpreted and sketched to provide a 2-dimensional representation (nets) of a three dimensional figure.
- Dimensions of solid figures may have fractional lengths.
- The volume of a solid figure is the number of same sized cubes filling the space so that there are no gaps and overlaps.

### **ESSENTIAL QUESTIONS**

- How can we find the area of figures?
- How can we cut and rearrange irregular polygons in order to find their area?
- How can we use one figure to determine the area of another?
- How do we measure the area of a shape without a formula for that shape?
- How are the areas of geometric figures related to each other?
- How can I use manipulatives and nets to help compute the surface areas of rectangular and triangular prisms?

- What kinds of problems can be solved using surface areas of rectangular and triangular prisms?
- How can I interpret and sketch views of rectangular and triangular prisms?
- How can I use formulas to determine the volume of right rectangular prisms?
- How can I determine the appropriate units of measure that should be used when computing the volume and surface area of prisms?
- What kinds of problems can be solved using volumes of fundamental solid figures?
- **In what ways can I measure the volume of a rectangular prism with fractional edge lengths?**

## **CONCEPTS & SKILLS TO MAINTAIN**

- number sense
- computation with whole numbers, fractions, and decimals, including application of order of operations
- multiplication and division of fractions
- formulas for finding area, surface area and volume
- area measures in square units and volume measures in cubic units
- properties of polygons, 2-D, and 3-D shapes

## **\*FLUENCY**

It is expected that students will continue to develop and practice strategies to build their capacity to become fluent in mathematics and mathematics computation. The eventual goal is automaticity with math facts. This automaticity is built within each student through strategy development and practice. The following section is presented in order to develop a common understanding of the ideas and terminology regarding fluency and automaticity in mathematics:

**Fluency:** Procedural fluency is defined as skill in carrying out procedures flexibly, accurately, efficiently, and appropriately. Fluent problem solving does not necessarily mean solving problems within a certain time limit, though there are reasonable limits on how long computation should take. Fluency is based on a deep understanding of quantity and number.

**Deep Understanding:** Teachers teach more than simply “how to get the answer” and instead support students’ ability to access concepts from a number of perspectives. Therefore students are able to see math as more than a set of mnemonics or discrete procedures. Students demonstrate deep conceptual understanding of foundational mathematics concepts by applying them to new situations, as well as writing and speaking about their understanding.

**Memorization:** The rapid recall of arithmetic facts or mathematical procedures. Memorization is often confused with fluency. Fluency implies a much richer kind of mathematical knowledge and experience.

**Number Sense:** Students consider the context of a problem, look at the numbers in a problem, make a decision about which strategy would be most efficient in each particular problem. Number sense is not a

deep understanding of a single strategy, but rather the ability to think flexibly between a variety of strategies in context.

**Fluent students:**

- flexibly use a combination of deep understanding, number sense, and memorization.
- are fluent in the necessary baseline functions in mathematics so that they are able to spend their thinking and processing time unpacking problems and making meaning from them.
- are able to articulate their reasoning.
- find solutions through a number of different paths.

For more about fluency, see: <http://www.youcubed.org/wp-content/uploads/2015/03/FluencyWithoutFear-2015.pdf> and: <http://joboaler.com/timed-tests-and-the-development-of-math-anxiety/>

## **STRATEGIES FOR TEACHING AND LEARNING**

It is very important for students to continue to physically manipulate materials and make connections to the symbolic and more abstract aspects of geometry. Exploring possible nets should be done by taking apart (unfolding) three-dimensional objects. This process is also foundational for the study of surface area of prisms. Building upon the understanding that a net is the two-dimensional representation of the object, students can apply the concept of area to find surface area. The surface area of a prism is the sum of the areas for each face.

Multiple strategies can be used to aid in the skill of determining the area of simple two-dimensional composite shapes. A beginning strategy should be to use rectangles and triangles, building upon shapes for which they can already determine area to create composite shapes. This process will reinforce the concept that composite shapes are created by joining together other shapes, and that the total area of the two-dimensional composite shape is the sum of the areas of all the parts.



A follow-up strategy is to place a composite shape on grid or dot paper. This aids in the decomposition of a shape into its foundational parts. Once the composite shape is decomposed, the area of each part can be determined and the sum of the area of each part is the total area.

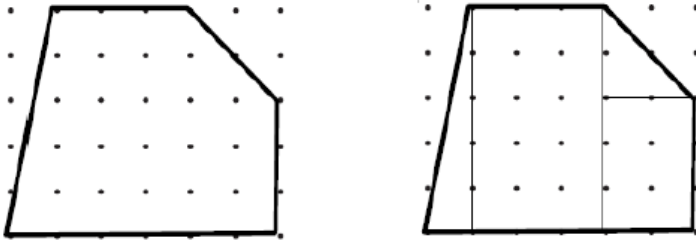

Fill prisms with cubes of different edge lengths (including fractional lengths) to explore the relationship between the length of the repeated measure and the number of units needed. An essential understanding to this strategy is the volume of a rectangular prism does not change when the units used to measure the volume changes. **Since focus in Grade 6 is to use fractional lengths to measure, if the same object is measured using one centimeter cubes and then measured using half centimeter cubes, the volume will appear to be eight times greater with the smaller unit. However, students need to understand that the value or the number of cubes is greater but the volume is the same.**

**Use a variety of manipulatives (e.g., geometric solids, nets, etc.) and real world objects (e.g., boxes, etc.) when exploring the measurement of 3-D and 2-D figures. When using concrete materials, always consider giving students the opportunity to define the unit of measurement, see/draw the unit of measurement (to scale), and predict the area, surface area, and/or volume of the object BEFORE calculating measurements. This will allow students to better understand the concepts of area, surface area, and volume, while also empowering them to better assess the reasonableness of their calculated measurements.**

### MISCONCEPTIONS

- *Students may believe the orientation of the figure changes the type of figure. They struggle with recognizing common figures in different orientation. For example, students may think that “square” rotated 45 degrees is no longer a square and instead is called a “diamond.” This impacts students’ ability to decompose composite figures and to appropriately apply formulas for area. Providing multiple orientations of objects within classroom examples and work is essential for students to overcome this misconception.*



- *Students may have trouble identifying the height of triangles and parallelograms. They confuse the height with always being a side length. Height is the altitude and must be perpendicular to the base (form a right angle).*
- *The height of a triangle can be one of the sides of the right angle in a right triangle. The height is an interior segment in an acute triangle, and it is an exterior segment (the base*



needs to be extended) in an obtuse triangle. See the screen shots below from the GeoGebra web site for examples of each of these types of triangles.

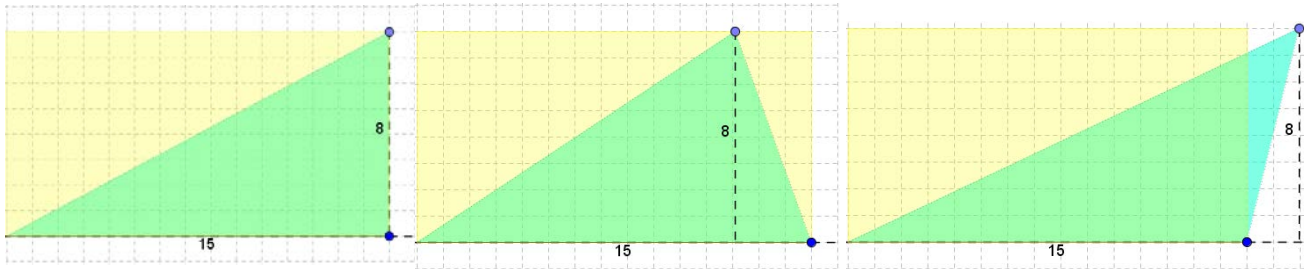

## **SELECTED TERMS AND SYMBOLS**

The following terms and symbols are often misunderstood. These concepts are not an inclusive list and should not be taught in isolation. However, due to evidence of frequent difficulty and misunderstanding associated with these concepts, instructors should pay particular attention to them and how their students are able to explain and apply them.

**The definitions below are for teacher reference only and are not to be memorized by the students.** Students should explore these concepts using models and real life examples. Students should understand the concepts involved and be able to recognize and/or demonstrate them with words, models, pictures, or numbers.

The websites below are interactive and include a math glossary suitable for middle school students. **Note – Different sources use different definitions. Please preview any website for alignment to the definitions given in the frameworks.**

<http://www.amathsdictionaryforkids.com/>

This web site has activities to help students more fully understand and retain new vocabulary

<http://intermath.coe.uga.edu/dictionary/homepg.asp>

Definitions and activities for these and other terms can be found on the Intermath website. Intermath is geared towards middle and high school students.

<http://www.corestandards.org/Math/Content/mathematics-glossary/glossary>

- **2-Dimensional:** A shape that only has two dimensions (such as width and height) and no thickness.
- **3-Dimensional:** An object that has height, width and depth (thickness), like any object in the real world.

- **Area:** The number of square units it takes to completely fill a space or surface.
- **Bases of a Prism:** The two faces formed by congruent polygons that lie in parallel planes, all of the other faces being parallelograms.
- **Composing:** Composing is putting two or more geometric figures.
- **Cubic Units:** Volume of the solids is measured in Cubic Units.
- **Dimension:** a measure of spatial length; a linear measurement
- **Decomposing:** subdividing a polygon
- **Edge:** The intersection of a pair of faces in a three-dimensional figure.
- **Equilateral Triangle:** A triangle which has all three of its sides equal in length.
- **Face:** One of the polygons that makes up a polyhedron.
- **Fractional edge length:** The length of each edge of the cube is a fraction.
- **Isosceles Triangle:** A triangle which has two of its sides equal in length.
- **Kite:** A quadrilateral with two distinct pairs of equal adjacent sides.  
A kite-shaped figure.
- **Lateral Faces:** In a prism, a face that is not a base of the figure.
- **Net:** A two-dimensional figure that, when folded, forms the surfaces of a three-dimensional object.
- **Parallelogram:** A quadrilateral with both pairs of opposite sides parallel.
- **Polygon:** A number of coplanar line segments, each connected end to end to form a closed shape. A *regular polygon* has all sides equal and all interior angles equal. An *irregular polygon* sides are not all the same length nor does the interior angles have the same measure.
- **Polyhedron:** A 3-dimensional figure that has polygons as faces.
- **Prism:** A polyhedron with two parallel and congruent faces, called bases, and all other faces that are parallelograms.

- **Quadrilaterals:** Four coplanar line segments linked end to end to create a closed figure. A 4-sided polygon.
- **Rectangle:** A 4-sided polygon where all interior angles are  $90^\circ$ .
- **Rectangular prism:** A solid (3-dimensional) object which has six faces that are rectangles.
- **Rhombus:** A quadrilateral with all four sides equal in length.
- **Right Triangle:** A triangle where one of its interior angles is a right angle ( $90$  degrees).
- **Right rectangular prism:** In a right prism, the lateral faces are each perpendicular to the bases.
- **Scalene Triangle:** A triangle where all three sides are different in length.
- **Square:** A quadrilateral that has four right angles and four equal sides.
- **Surface area:** The total area of the 2-dimensional surfaces that make up a 3-dimensional object.
- **Trapezoid:** A quadrilateral which has at least one pair of parallel sides.
- **Triangles:** A closed figure consisting of three line segments linked end-to-end. A 3-sided polygon
- **Triangular prism:** A prism whose bases are triangles. A solid (3-dimensional object what has five faces: three rectangles and two bases.
- **Vertices:** The common endpoint of two or more rays or line segments
- **Volume:** The amount of space occupied by an object.
- **Volume of a Prism:** The area of a base times the height. The number of cubic units to fill a prism.

## INSTRUCTIONAL RESOURCES AND TOOLS

- Cubes of fractional edge length
- Squares that can be joined together used to develop possible nets for a cube
- 3-D manipulatives that can be unfolded into nets
- Use floor plans as a real world situation for finding the area of composite shapes.
- [1 cm dot grid paper](#) and [isometric dot grid paper](#)
- [Geoboard Recording Paper](#)
- **Cereal boxes, TV dinner cartons, etc. for creating nets (you may need to cut tabs)**
- Students can explore the area of triangles using the following Illuminations web site: <http://illuminations.nctm.org/ActivityDetail.aspx?ID=108>. On this site, students are able to move all of the three vertices of the triangle. The program gives the length of the base and the height, as well as the area of the triangle. This information can be added to a table, allowing students to look for patterns. Students should recognize that no matter how the shape of the triangle changes, the height of the triangle is always perpendicular to the base.
- When exploring parallelograms, student can explore the areas of a rectangle and a parallelogram with the same base and height on the following GeoGebra web site: <http://www.geogebra.org/en/upload/files/english/Knote/Area/parallelograms.html>.

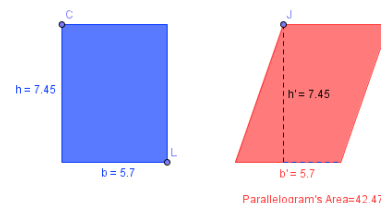

Or students can explore the area of a parallelogram by “cutting” off a triangle and sliding it to the other side to create a square with the same area.

Parallelogram's Area=40

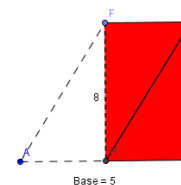

## FORMATIVE ASSESSMENT LESSONS (FAL)

**Formative Assessment Lessons** are intended to support teachers in formative assessment. They reveal and develop students’ understanding of key mathematical ideas and applications. These lessons enable teachers and students to monitor in more detail their progress towards the targets of the standards. They assess students’ understanding of important concepts and problem solving performance, and help teachers and their students to work effectively together to move each student’s mathematical reasoning forward.

More information on Formative Assessment Lessons may be found in the Comprehensive Course Guide.

## **SPOTLIGHT TASKS**

For middle and high schools, each Georgia Standards of Excellence mathematics unit includes at least one Spotlight Task. The Spotlight Tasks serve as exemplars for the use of the Standards for Mathematical Practice, appropriate unit-level Georgia Standards of Excellence, and research-based pedagogical strategies for instruction and engagement. Each task includes teacher commentary and support for classroom implementation. Some of the Spotlight Tasks are revisions of existing Georgia tasks and some are newly created. Additionally, some of the Spotlight Tasks are 3-Act Tasks based on 3-Act Problems from Dan Meyer and Problem-Based Learning from Robert Kaplinsky

## **3-ACT TASKS**

A Three-Act Task is a whole group mathematics task consisting of 3 distinct parts: an engaging and perplexing Act One, an information and solution seeking Act Two, and a solution discussion and solution revealing Act Three.

More information along with guidelines for 3-Act Tasks may be found in the Comprehensive Course Guide.

**Georgia Department of Education**  
 Georgia Standards of Excellence Framework  
*GSE Grade 6 Mathematics • Unit 5*

**TASKS**

<b>Task</b>	<b>Task Type / Grouping Strategy</b>	<b>Content Addressed</b>	<b>Performance Standards</b>
** <a href="#">Who Put the Tang in Tangram?</a>	Learning Task <i>Individual/Partner Task</i>	Find area of regular and irregular polygons	MGSE6.G.1
** <a href="#">Rectangle Wraparound</a>	Learning Task <i>Individual/Partner Task</i>	Find area of regular and irregular polygons	MGSE6.G.1
<a href="#">Finding Areas of Polygons</a> (Spotlight Task)	Learning Task <i>Individual/Partner Task</i>	Find area of irregular polygons	MGSE6.G.1
<a href="#">What's My Area?</a>	Learning Task <i>Individual/Partner Task</i>	Find area of regular and irregular polygons; apply to solve real-world problems	MGSE6.G.1
** <a href="#">King Arthur's New Table</a>	Learning Task <i>Partner/Small Group Task</i>	Find area of regular and irregular polygons; apply to solve real problems	MGSE6.G.1
<a href="#">Area of Composite Figures</a> (FAL)	Formative Assessment Lesson <i>Problem Solving Task</i>	Find area of regular and irregular polygons; apply to solve real problems	MGSE6.G.1
** <a href="#">Finding Surface Area</a>	Learning Task <i>Individual/Partner Task</i>	Find Surface Area of rectangular prisms, triangular prisms, rectangular pyramids, and triangular pyramids	MGSE6.G.4
** <a href="#">How Many Ways?</a>	Learning Task <i>Partner/Small Group Task</i>	Find area of regular and irregular polygons; apply to solve real	MGSE6.G.2
<a href="#">Banana Bread</a>	Learning Task <i>Partner/ Small Group</i>	Find volume of rectangular prisms.	MGSE6.G.2
** <a href="#">Volume and Cubes</a>	Learning Task <i>Individual/Partner Task</i>	Finding volume of rectangular prisms. Focus on packing with cubes with fractional sides.	MGSE6.G.2
<a href="#">Packaging Our Goods</a> (Spotlight Task)	Learning Task <i>Individual/Partner Task</i>	Finding volume and surface area for real-world problems	MGSE6.G.2 MGSE6.G.4

**Georgia Department of Education**  
 Georgia Standards of Excellence Framework  
*GSE Grade 6 Mathematics • Unit 5*

<a href="#">Painting the Barn</a> (Spotlight Task)	Learning Task <i>Individual/ Partner Task</i>	Finding surface area for real-world problems	MGSE6.G.4
<a href="#">Designing Candy Cartons</a>	Formative Assessment Lesson <i>Problem Solving Task</i>	Finding volume and surface area for real-world problems	MGSE6.G.1 MGSE6.G.2 MGSE6.G.4
<a href="#">Candle Box</a>	Short Cycle Task	Finding volume and surface area for real-world problems	MGSE6.G.1 MGSE6.G.2 MGSE6.G.4
<a href="#">Smoothie Box</a>	Short Cycle Task	Finding volume and surface area for real-world problems	MGSE6.G.1 MGSE6.G.2 MGSE6.G.4
<a href="#">Boxing Bracelets</a>	Learning Task <i>Partner/Small Group Task</i>	Apply formulas to find volume and surface area for real-world problems	MGSE6.G.2 MGSE6.G.4
<a href="#">The File Cabinet</a> (Spotlight Task)	Learning Task <i>Partner/Small Group Task</i>	Apply formulas to find surface area for real-life problems	MGSE6.G.4
Culminating Task <a href="#">STEM Fish Tank Foam Packaging Design</a>	Performance Task <i>Individual Task</i>	Apply formulas to find volume and surface area for real-world problems	MGSE6.G.2 MGSE6.G.4

## **\*\*Who Put The Tang In Tangram?**

Adapted from a lesson on the Utah Education Network [www.uen.org](http://www.uen.org)

Tangram clip art from <http://www.who.int/world-health-day/previous/2005/infomaterials/en/>

[Back to Task Table](#)



*In this hands-on task, students determine the area of tangram pieces without using formulas. Students also develop and use formulas to determine the area of squares, rectangles, triangles, and parallelograms.*

### **STANDARDS FOR MATHEMATICAL CONTENT**

**MGSE6.G.1 Find area of right triangles, other triangles, quadrilaterals, and polygons by composing into rectangles or decomposing into triangles and other shapes; apply these techniques in the context of solving real-world and mathematical problems.**

### **STANDARDS FOR MATHEMATICAL PRACTICE**

- 1. Make sense of problems and persevere in solving them.** Given a two dimensional figure students will solve for the area by composing and decomposing.
- 3. Construct viable arguments and critique the reasoning of others.** Students will be able to review solutions to justify (verbally and written) why the solutions are reasonable.
- 4. Model with mathematics.** Use hands on/virtual manipulatives (tangrams) using every day two-dimensional and three-dimensional shapes.
- 5. Use appropriate tools strategically.** Students will use a tangrams and dot paper to solve for area.
- 6. Attend to precision.** Students will use appropriate measurement units and correct terminology to justify reasonable solutions.
- 7. Look for and make use of structure.** Students compose and decompose two-dimensional figures to find areas.
- 8. Look for and express regularity in repeated reasoning.** Students will explain why decompose and composed figures to find of irregular polygons.

### **ESSENTIAL QUESTIONS**

- How can shapes be composed to create new shapes?
- How can a shape be decomposed into smaller shapes?
- How do we figure the area of a shape without a formula for that shape?

### **MATERIALS**

- *The Warlord's Puzzle* by Virginia Walton Pilegard, or similar book about tangrams
- *Grandfather Tang* by Ann Tompert, or a similar book about tangrams
- “Who Put the Tang in Tangrams? Finding Areas” student recording sheet (2 pages)
- “Who Put the Tang in Tangrams? Deriving Formula I” student recording sheet (2 pages)
- “Who Put the Tang in Tangrams? Deriving Formula II” student recording sheet
- Tangram sets
- Geoboards, Rubber bands
- [Geoboard Recording Paper](#)
- 9 x 12 art paper



## **TASK COMMENTS**

[Geogebra.org](http://Geogebra.org) is a free interactive website that allows users to create regular and irregular polygons to find area. Teachers and students can use this to compose and decompose shapes to solve real-world problems.

As an introduction to this task, the book *The Warlord's Puzzle* by Virginia Walton Pilegard or similar book about tangrams can be read to the students. After the story, guide students to create their own tangram pieces through paper folding. Directions with illustrations can be found below and at the following web site: <http://mathforum.org/trscavo/tangrams/construct.html>.

- Fold a 9 x 12 piece of art paper to form a square. Cut off the extra piece at the bottom and discard.
- Cut the square in half on the diagonal fold to form two triangles.
- Take one of the triangles and fold it in half to form two smaller congruent triangles. Cut along the fold.
- Take the other large triangle and make a small pinch crease in the middle of the baseline (longest side) to identify the center. Take the apex of the triangle (the vertex opposite the longest side) and fold it to touch the center of the baseline. This forms a trapezoid.
- Cut along the fold line. This gives you a trapezoid and a small triangle.
- Fold the trapezoid in half (two congruent shapes) and cut along the fold line.
- Take one half of the trapezoid and fold the pointed end to form a small square. Cut along the fold. This will give you a small square and a small triangle.
- Take the remaining half of the trapezoid. Fold one of the corners of the square end to form a small triangle and a parallelogram. Cut along the fold.

As you deconstruct the square, discuss the relationships between the pieces. Once complete with a full set (One small square, two small congruent triangles, two large congruent triangles, a medium size triangle and a parallelogram), ask students to experiment with the shapes to create new figures.

To start this task, give each student a set of plastic Tangrams to use for this task (they are easier to trace than the paper ones). Ask students to find the two small congruent triangles and review the definition of congruent: same size, same shape. Put them together to make a square. Ask students what the area of this shape would be and ask them to explain how they know. (*Because the square formed with the two small triangles is the congruent to the tangram square, its area must be the same  $1 u^2$ .*) Next, ask students to take just one of the small triangles. Ask students what its area would be and ask them to explain how they know. Remember to relate it to the square. (*The area of each small triangle is half of the area of the square, so its area is  $\frac{1}{2} u^2$ .*) Give students the time to try to determine how to make the shapes before students share their work. This processing time for thinking and experimenting will help students develop their spatial reasoning.

### **BACKGROUND KNOWLEDGE**

Students will need to approach this task with the following prerequisite knowledge:

- Experience with common plane figures and the identification of their sides and angles.
- Familiarity with how to use a geoboard and transfer shapes on the geoboard to geoboard paper.
- Knowledge of area and congruence.
- Understanding of the area of a rectangle and its formula.

Students will be figuring the area of each of the tangram pieces by comparing them to the small square. The small square will be “one square unit”. Therefore, the length and width are both one unit because  $1 \times 1 = 1$ .

### **Questions/Prompts for Formative Student Assessment**

- What is the area of this shape? How do you know?
- What shapes have the same area as the area of this shape?
- What shapes did you use to create a figure congruent to this figure? What are the areas of those shapes used?
- What could you add to find the area of this shape?

### **Questions for Teacher Reflection**

- Which students are able to find a relationship of each tangram piece to the area of the square?
- Which students need to completely cover a figure with tangram pieces in order to find its area?
- Which students are able to use the relationships between tangram pieces to find the area of figures?
- Did students recognize that the area of a figure can be found by finding the area of pieces of the figure and then adding them together?

### **DIFFERENTIATION**

#### **Extension**

- There are different ways to create many of the shapes on the “Who Put the Tang in Tangram? Finding Areas” student recording sheet. Allow students to explore these shapes to see if they can find different ways to create them using the tangrams.
- Using a Geoboard and Geoboard recording paper (available at [http://www.wiley.com/college/reys/0470403063/appendixc/masters/geoboard\\_recording.html](http://www.wiley.com/college/reys/0470403063/appendixc/masters/geoboard_recording.html)). Ask students to create and record as many different parallelograms as they can that have an area of  $\frac{1}{2}$ , 1, or 2 square units. Ask student to identify and give the measure of a base and height for each parallelogram.







## **Intervention**

- Do not have students with fine motor control difficulties trace the shapes; just let them manipulate the tangrams. Also, students may be given a copy of the tangram puzzle so they just have to cut out the shapes, not fold to make the shapes.
- It might be helpful to give some students two sets of tangrams in different colors so they can more easily see the relationships between the shapes.





## **TECHNOLOGY CONNECTIONS**

- <http://illuminations.nctm.org/ActivityDetail.aspx?ID=108> Interactive triangle and parallelogram applets. Allows students to explore the relationship between the base and height in any type of triangle or parallelogram. (Do not use the trapezoid feature.) This is a great resource help clarify the misconception about height of a triangle.
- <http://www.geogebra.org/en/upload/files/english/Victoria/TriangleArea.html> Interactive triangle, students can find the area given the base and height.
- <http://www.geogebra.org/en/upload/files/english/Knote/Area/Parallelogram2.html> Interactive parallelogram, students can find the area given the base and height, as well as move a triangular piece to create a rectangle.
- <http://www.geogebra.org/en/upload/files/english/Knote/Area/parallelograms.html> Interactive parallelogram, students can find the area given the base and height.

*Sample solutions for the “Who Put the Tang in Tangram? Finding Areas” student recording sheet are shown below.*

Figure	Show your work	Area of Figure (in square units)
Small Triangle 	Two small triangles can be arranged to make a square congruent to the square with an area of $1 u^2$ .	The triangle is half of the square so it must have an area of $\frac{1}{2} u^2$ .
Medium Triangle 	Two small triangles can be arranged as shown to make a triangle congruent to the medium triangle.	Since the area of each small triangle is $\frac{1}{2} u^2$ , the area of the medium triangle must be $1 u^2$ .
Large Triangle (Use the square) 	The square and two small triangles can be arranged as shown to make a triangle congruent to the large triangle.	Since the area of each small triangle is $\frac{1}{2} u^2$ and the area of the square is $1 u^2$ , the area of the large triangle must be $2 u^2 \left( \frac{1}{2} u^2 + \frac{1}{2} u^2 + 1 u^2 \right)$ .
Parallelogram 	Two small triangles can be arranged as shown to make a parallelogram congruent to the given parallelogram.	Since the area of each small triangle is $\frac{1}{2} u^2$ , the area of the parallelogram must be $1 u^2$ .
Trapezoid 	A small triangle and the parallelogram can be combined as shown to create the trapezoid.	Since the area of a small triangle is $\frac{1}{2} u^2$ and the area of the parallelogram $1 u^2$ , the area of the large triangle must be $1 \frac{1}{2} u^2 \left( \frac{1}{2} u^2 + 1 u^2 \right)$ .
Two small and one medium triangle 	Two small and one medium triangle can be combined as shown to make this square.	Since the area of each small triangle is $\frac{1}{2} u^2$ and the area of the medium triangle is $1 u^2$ , the area of the triangle must be $2 u^2 \left( \frac{1}{2} u^2 + \frac{1}{2} u^2 + 1 u^2 \right)$ .
Rectangle 	Two small triangles and the parallelogram can be combined as shown to create this rectangle.	Since the area of each small triangle is $\frac{1}{2} u^2$ and the area of the parallelogram is $1 u^2$ , the area of the rectangle must be $2 u^2 \left( \frac{1}{2} u^2 + \frac{1}{2} u^2 + 1 u^2 \right)$ .

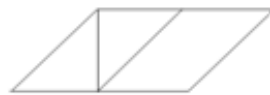
**Georgia Department of Education**  
 Georgia Standards of Excellence Framework  
*GSE Grade 6 Mathematics • Unit 5*

Figure Sketch it below	Show your work	Area of Figure (in square units)
Triangle congruent to a large triangle (Do not use the square) 	Two small triangles and the medium triangle can be arranged to make a triangle congruent to the large triangle.	Since the area of each small triangle is $\frac{1}{2} u^2$ and the area of the medium triangle is $1 u^2$ , the area of the large triangle must be $2 u^2 \left( \frac{1}{2} u^2 + \frac{1}{2} u^2 + 1 u^2 \right)$ .
Trapezoid (Different from the one page 1) 	One possible trapezoid can be made using two small triangles and the parallelogram.	Since the area of each small triangle is $\frac{1}{2} u^2$ and the area of the parallelogram is $1 u^2$ , the area of the trapezoid must be $2 u^2 \left( \frac{1}{2} u^2 + \frac{1}{2} u^2 + 1 u^2 \right)$ .
Parallelogram (Different from the one on page 1) 	One possible parallelogram can be made as shown using two small triangles and the parallelogram.	Since the area of each small triangle is $\frac{1}{2} u^2$ and the area of the parallelogram is $1 u^2$ , the area of the created parallelogram must be $2 u^2 \left( \frac{1}{2} u^2 + \frac{1}{2} u^2 + 1 u^2 \right)$ .
Pentagon 	One possible pentagon can be made as shown using two small triangles, the square and the medium triangle.	Since the area of each small triangle is $\frac{1}{2} u^2$ , the area of the square is $1 u^2$ , and the area of the medium triangle is $1 u^2$ , the area of the pentagon must be $3 u^2 \left( \frac{1}{2} u^2 + \frac{1}{2} u^2 + 1 u^2 + 1 u^2 \right)$ .
Square using all 7 pieces 	One possible square can be made as shown all seven pieces.	Since the area of each small triangle is $\frac{1}{2} u^2$ , the area of the square is $1 u^2$ , the area of the medium triangle is $1 u^2$ , the area of the parallelogram is $1 u^2$ , and the area each of the large triangles is $2 u^2$ , the area of the square must be $8 u^2 \left( \frac{1}{2} u^2 + \frac{1}{2} u^2 + 1 u^2 + 1 u^2 + 2 u^2 + 2 u^2 \right)$ .

Name \_\_\_\_\_ Date \_\_\_\_\_

### Who Put the Tang in Tangram?



Find the area of the following figures.

Figure	Show your work	Area of Figure (in square units)
Small Triangle 		
Medium Triangle 		
Large Triangle 		
Parallelogram 		
Trapezoid 		
Two small and one medium triangles 		
Rectangle 		

**Georgia Department of Education**  
Georgia Standards of Excellence Framework  
*GSE Grade 6 Mathematics • Unit 5*

<b>Figure Sketch it below</b>	<b>Show your work</b>	<b>Area of Figure (in square units)</b>
Triangle congruent to a large triangle (Do not use the square)		
Trapezoid (Different from the one page 1)		
Parellelogram (Different from the one on page 1)		
Pentagon		
Square using all 7 pieces		

## **\*\*Rectangle Wrap-Around**

[Back to Task Table](#)

*In this hands-on task, students will first measure the area of polygons without using formulas and then make sense of the formulas by reasoning about the models.*

### **STANDARDS FOR MATHEMATICAL CONTENT**

**MGSE6.G.1 Find area of right triangles, other triangles, quadrilaterals, and polygons by composing into rectangles or decomposing into triangles and other shapes; apply these techniques in the context of solving real-world and mathematical problems.**

### **STANDARDS FOR MATHEMATICAL PRACTICE**

- 1. Make sense of problems and persevere in solving them.** Given a two-dimensional figure, students will measure area by composing and decomposing.
- 3. Construct viable arguments and critique the reasoning of others.** Students will be able to review solutions to justify (verbally and written) why the solutions are reasonable.
- 4. Model with mathematics. Use geoboards and grid paper to model polygons, and connect these models to reason about the corresponding area formulas.**
- 6. Attend to precision.** Students will use appropriate measurement units and correct terminology to justify reasonable solutions.
- 7. Look for and make use of structure.** Students compose and decompose two-dimensional figures to find areas, reason about formulas for calculating area, and then conjecture about whether or not the formulas will always work.

### **ESSENTIAL QUESTIONS**

- How are the areas of geometric figures related to each other?
- How do we figure the area of a shape without a formula for that shape?

### **MATERIALS**

- Geoboards, Rubber bands
- **Scissors**
- Student recording sheet (included)



## Rectangle Wrap-Around

Name \_\_\_\_\_ Date \_\_\_\_\_

1. On your geoboard, make a square with an area of nine square units. Record it on the given geoboard.

- a. Determine its length and its width.  **$3 \times 3$**   
b. Write a formula for the area of the square.

$$A = s \times s; A = s^2; A = bh$$

- c. Divide the square in half by drawing a diagonal in the square.

- d. What two congruent shapes have you made?

***2 triangles***

- e. What is the area of one triangle?  **$A = \frac{1}{2}bh$**

Explain how you found the area of one triangle. Show all work on the geoboard.

***the formula for the square, divided in half***

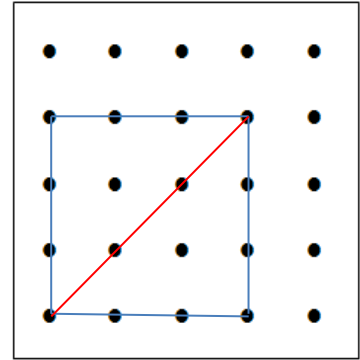

2. Make a different rectangle on your geoboard. Record it on the given geoboard.

- a. Determine its length and its width. ***Answers will vary***

- b. Write a formula for the area of the rectangle.

$$A = bh$$

- c. Divide the rectangle in half by drawing a diagonal in the square.

- d. What two congruent shapes have you made?

***2 triangles***

- e. What is the area of one triangle?  **$A = \frac{1}{2}bh$**

Explain how you found the area of one triangle. Show all work on the geoboard.

---

---

---

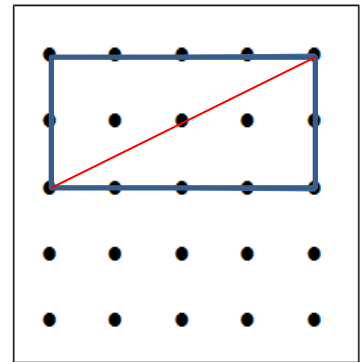

3. Make another different rectangle on your geoboard. How would you find the area of a triangle created in your rectangle by a diagonal? Explain how you found the area of the triangle. Record your work on the geoboard.

*see explanation in question 2*

---



---



---



---

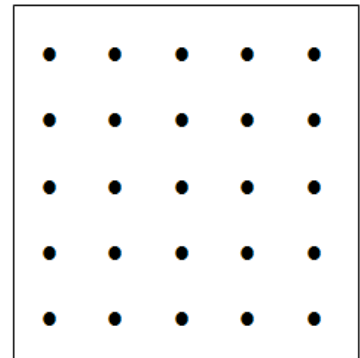

4. What patterns do you notice about finding the area of a triangle?

*It is always half the area of the rectangle with sides having the same base and height of the triangle*

5. What is a formula we could use to find the area of a triangle?

*$A = \frac{1}{2} bh$*

6. Use the formula to find the area of the triangles below. Use another method to find the area of each triangle. Verify that the area is the same using both methods. Show all work.

*One possible other method using composing and decomposing:*

*Area rectangle 1 =  $2 \times 1 = 2$  square units  
 Area of triangle, =  $\frac{1}{2} 2 \times 1 = 1$  square unit*

*Area of rectangle 1 =  $1 \times 1 = 1$  sq unit  
 Area of triangle 1 =  $\frac{1}{2} bh = \frac{1}{2}$  sq unit*

*Area of rectangle 2 =  $2 \times 3 = 6$  square units  
 Area of triangle 2 =  $\frac{1}{2} 2 \times 3 = 3$  square units  
 The new area is  $8 - 1 - 3 = \underline{4 \text{ sq un}}$*

*Area of rectangle 2 =  $1 \times 4 = 4$  sq units  
 Area of triangle 2 =  $\frac{1}{2} \times 1 \times 4 = 2$  sq un  
 The new area is  $4 - \frac{1}{2} - 2 = \underline{1 \frac{1}{2} \text{ sq un}}$*

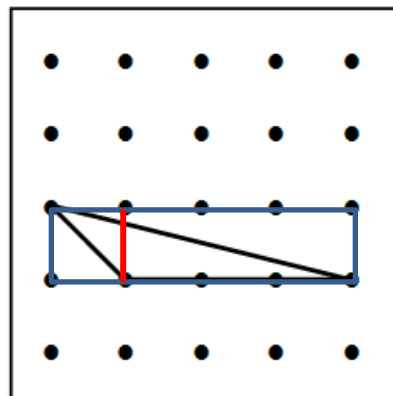
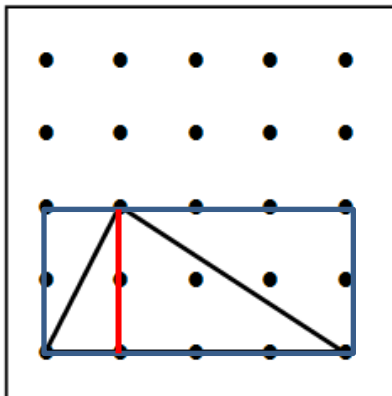

Name \_\_\_\_\_ Date \_\_\_\_\_

- Use a straight edge to draw a parallelogram in one of the grids at the bottom of the page.
- Carefully cut out your parallelogram.
- Follow a line on the graph paper to cut off a triangle from one end of your parallelogram. See the diagram below.

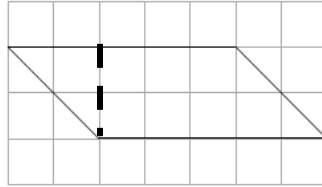

- Slide the triangle to the opposite side of your parallelogram.

What shape is formed? *rectangle*

- What are the dimensions of the shape? *2 x 5* What is the area? *10 sq units*

- Do you think this will always work? Explain your thinking.

*Yes, every parallelogram can be decomposed and composed in this manner, resulting in the formula/method of finding the area,  $A = bh$*

- Use the grid paper below to draw a different parallelogram. Find the area of the area of the parallelogram. *Answers will vary.*

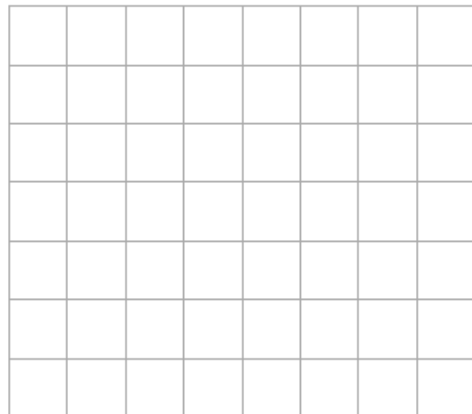
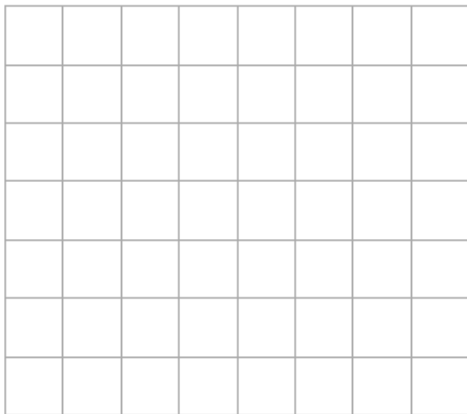

## Rectangle Wrap-Around

Name \_\_\_\_\_ Date \_\_\_\_\_

1. On your geoboard, make a square with an area of nine square units. Record it on the given geoboard.

a. Determine its length and its width. \_\_\_\_\_

b. Write a formula for the area of the square.  
\_\_\_\_\_

c. Divide the square in half by drawing a diagonal in the square.

d. What two congruent shapes have you made?  
\_\_\_\_\_

e. What is the area of one triangle? \_\_\_\_\_

Explain how you found the area of one triangle. Show all work on the geoboard.

\_\_\_\_\_  
\_\_\_\_\_  
\_\_\_\_\_

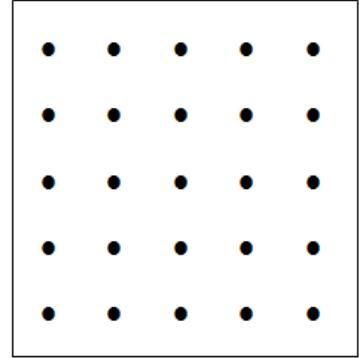

2. Make a different rectangle on your geoboard. Record it on the given geoboard.

a. Determine its length and its width. \_\_\_\_\_

b. Write a formula for the area of the rectangle.  
\_\_\_\_\_

c. Divide the rectangle in half by drawing a diagonal in the square.

d. What two congruent shapes have you made?  
\_\_\_\_\_

e. What is the area of one triangle? \_\_\_\_\_

Explain how you found the area of one triangle. Show all work on the geoboard.

\_\_\_\_\_  
\_\_\_\_\_  
\_\_\_\_\_

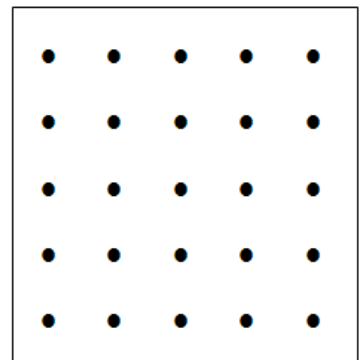

3. Make another different rectangle on your geoboard. How would you find the area of a triangle created in your rectangle by a diagonal? Explain how you found the area of the triangle. Record your work on the geoboard.

---

---

---

---

---

---

---

---

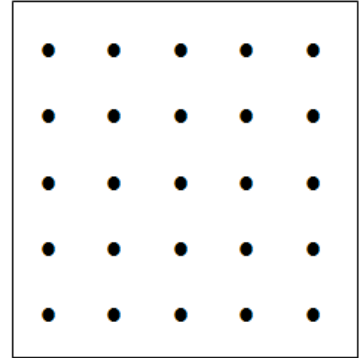

4. What do patterns do you notice about finding the area of a triangle?

---

---

---

---

5. What is a formula we could use to find the area of a triangle?

---

---

6. Use the formula to find the area of the triangles below. Use another method to find the area of each triangle. Verify that the area is the same using both methods. Show all work.

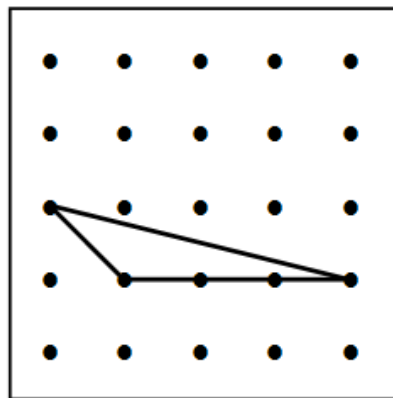
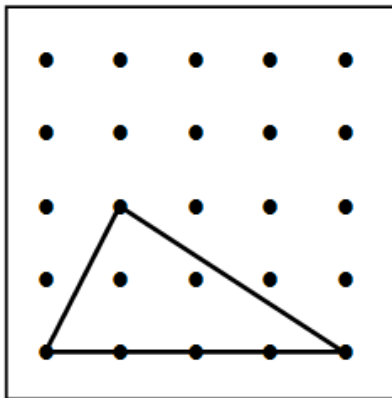

Name \_\_\_\_\_ Date \_\_\_\_\_

7. Use a straight edge to draw a parallelogram in one of the grids at the bottom of the page.
8. Carefully cut out your parallelogram.
9. Follow a line on the graph paper to cut off a triangle from one end of your parallelogram. See the diagram below.

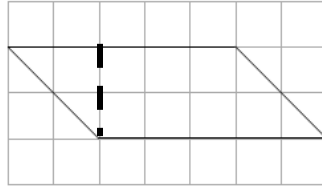

10. Slide the triangle to the opposite side of your parallelogram.  
 What shape is formed? \_\_\_\_\_
11. What are the dimensions of the shape? \_\_\_\_\_ What is the area? \_\_\_\_\_
12. Do you think this will always work? Explain your thinking.

---



---



---

13. Use the grid paper below to draw a different parallelogram. Find the area of the area of the parallelogram.

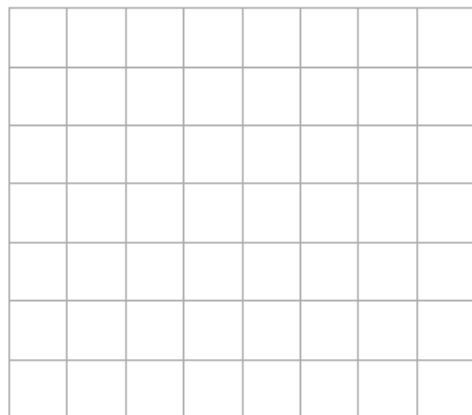
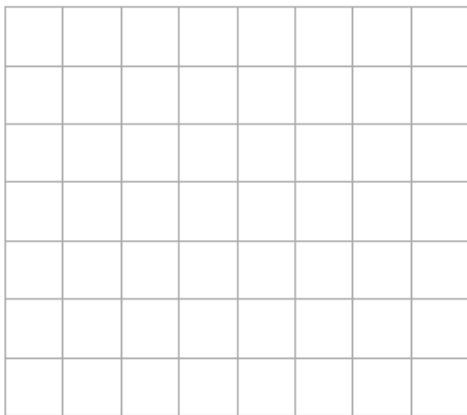

## **Finding Areas of Polygons (Spotlight Task)**

[Back to Task Table](#)

Task adapted from <http://blog.mrmeyer.com/2013/teaching-with-three-act-tasks-act-one/>

*In this task, students will predict the area of irregular polygons and then calculate the area by composing and decomposing rectangles (rather than formulas).*

### **STANDARDS FOR MATHEMATICAL CONTENT**

**MGSE6.G.1 Find area of right triangles, other triangles, quadrilaterals, and polygons by composing into rectangles or decomposing into triangles and other shapes; apply these techniques in the context of solving real-world and mathematical problems.**

### **STANDARDS FOR MATHEMATICAL PRACTICE**

- 1. Make sense of problems and persevere in solving them.** Given a two dimensional figure students will solve for the area by composing and decomposing.
- 3. Construct viable arguments and critique the reasoning of others.** Students will be able to review solutions to justify (verbally and written) why the solutions are reasonable.
- 4. Model with mathematics.** Use geoboards, graphs, dot paper to compose and decompose figures in order to calculate their areas.
- 5. Use appropriate tools strategically.** Students will use graph and dot paper to solve for area.
- 8. Look for and express regularity in repeated reasoning.** Students will explain why decompose and composed figures to find of irregular polygons.

### **ESSENTIAL QUESTIONS**

- How can we use one figure to determine the area of another?
- How can shapes be composed to form other shapes?
- How can shapes be decomposed to find the area of irregular shapes?

### **MATERIALS**

- Colored pencils
- Rulers
- Copies of figures drawn on graph paper

### **DIFFERENTIATION**

Students who struggle to visualize figures composing figures may need repeated practice with simple figures, which are simple to create on graph paper. Using colored pencils to highlight each figure helps with visualization and insuring each part is included, no gaps, no overlaps.

Students who quickly grasp the concept and are successful with these figures can be given more challenging figures, and can create figures to exchange with classmates.

## Finding Areas of Polygons (Spotlight Task)

Name \_\_\_\_\_ Date \_\_\_\_\_

A. WHAT IS THE AREA OF THE FIGURE BELOW?

Write down an estimate that you know is too *low*. *Answers will vary. All students have access to participating with open questions such as this.*

Write down an estimate that you know is too *high*. *Answers will vary. All students have access to participating with open questions such as this.*

Write down your best *guess*.

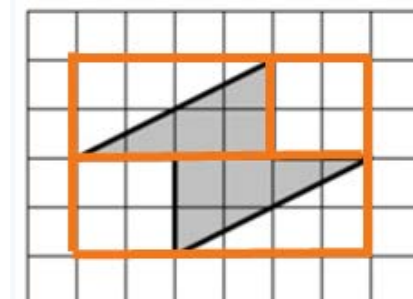
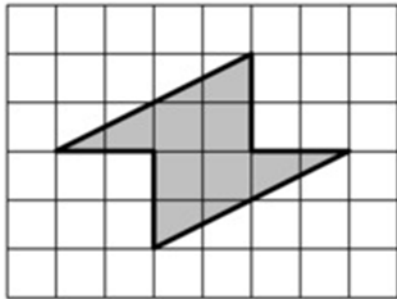

B. WHAT IS THE AREA OF THE FIGURE BELOW?

How can you find the area of Figure B? *By composing into 3 rectangles,  $6 + 6 + 1 = 13$  square units; by decomposing from a  $4 \times 5$  rectangle,  $20 - 3 - 1 - 3 = 13 u^2$*

How is this figure like, and unlike, Figure A? *Can be composed or decomposed to find the area. Note, with all figures, students may find other ways to compose and decompose.*

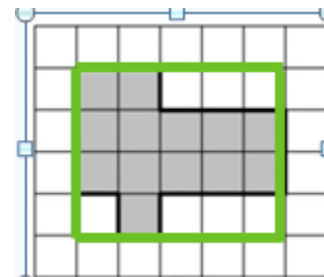
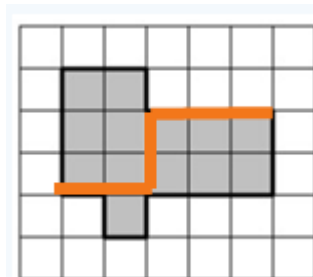
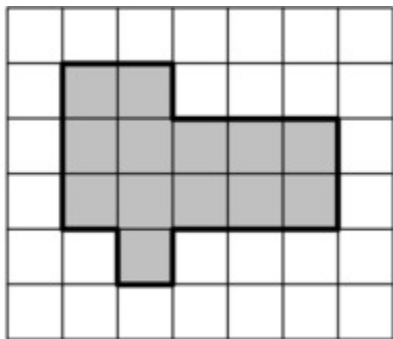



C. WHAT IS THE AREA OF THE FIGURE BELOW?

Describe how you can find the area of Figure C. Compare this to your method in Figures A and B.

*This figure can best be decomposed because of the oblique sides.*

*Inscribe the figure in a  $4 \times 5$  rectangle =  $20 u^2$ .*

*Making sure the edges of the figure form BISECTORS of the rectangles formed, create a  $2 \times 5$  rectangle on top (-5), create a  $2 \times 4$  rectangle on bottom (-4), and create a  $4 \times 1$  rectangle on the left (-2), so  $20 - 11 = 9 u^2$*

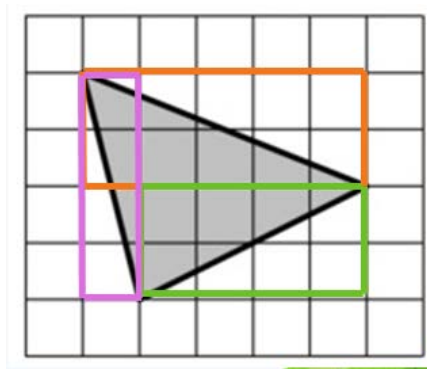
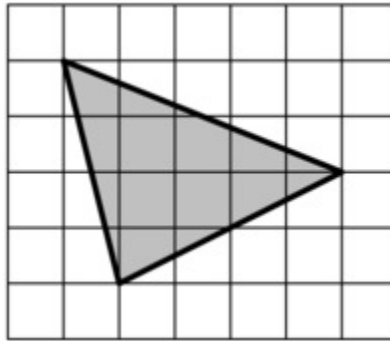

## Finding Areas of Polygons (Spotlight Task)

Name \_\_\_\_\_ Date \_\_\_\_\_

A. WHAT IS THE AREA OF THE FIGURE BELOW?

Write down an estimate that you know is too *low*.

Write down an estimate that you know is too *high*.

Write down your best *guess*.

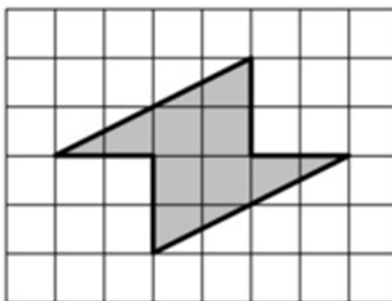

B. WHAT IS THE AREA OF THE FIGURE BELOW?

How can you find the area of Figure B?

How is this figure like, and unlike, Figure A?

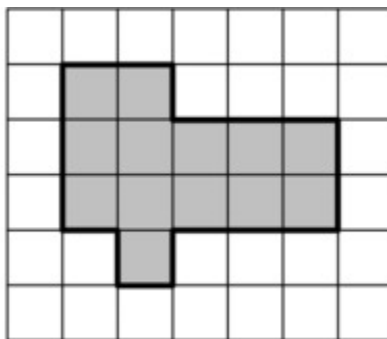

**C. WHAT IS THE AREA OF THE FIGURE BELOW?**

Describe how you can find the area of Figure C. Compare this to your method in Figures A and B.

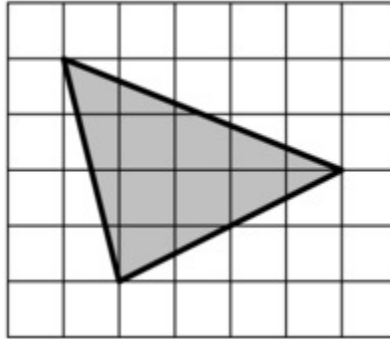

## What's My Area?

[Back to Task Table](#)

*In this task, students decompose an irregular geometric figure into smaller regular figures in order to find the area of the composite figure.*



### STANDARDS FOR MATHEMATICAL CONTENT

**MGSE6.G.1 Find area of right triangles, other triangles, quadrilaterals, and polygons by composing into rectangles or decomposing into triangles and other shapes; apply these techniques in the context of solving real-world and mathematical problems.**

### STANDARDS FOR MATHEMATICAL PRACTICE

- 1. Make sense of problems and persevere in solving them.** Given an irregular two dimensional figure the student will compose and decompose to find the area.
- 2. Reason abstractly and quantitatively** – Students will use their understanding of polygons in solving with area. Students will be able to see and justify the reasoning for decomposing and composing an irregular polygon to solve for area.
- 3. Construct viable arguments and critique the reasoning of others.** Students will be able to review solutions to justify (verbally and written) why the solutions are reasonable.
- 4. Model with mathematics.** Students will use hands on/virtual manipulatives.
- 5. Use appropriate tools strategically.** Students will use a ruler, graph paper two-dimensional shapes to solve for area.
- 6. Attend to precision.** Students will use appropriate measurement units (square units vs. cubic units) and correct terminology to justify reasonable solutions.
- 7. Look for and make use of structure.** Students also decompose two-dimensional figures to find areas.
- 8. Look for and express regularity in repeated reasoning.** Students will explain why the formula or process is used to solve given problems.

### ESSENTIAL QUESTIONS

- How can we use one figure to determine the area of another?
- How can shapes be composed and decomposed to create new shapes?
- How can the formulas for the area of plane figures be used to solve problems?

### MATERIALS

- “What’s My Area?” student recording sheet
- Metric rulers
- Geoboard and rubber bands (optional)
- Pattern blocks (optional)
- Calculators

### TASK COMMENTS

This task can be introduced by asking students if there is a formula to find the area of the figure. The students should recognize that there is no formula. Therefore, challenge students to identify a process they could use to find the area. Allow the students to use manipulatives such as a Geoboard or Pattern Blocks to explore the figure and find area.

**BACKGROUND KNOWLEDGE**

Since as early as grade 3 GSE, students have had experience with: calculating the area of common plane figures, using a ruler to measure lengths of segments, and how to measure to the nearest millimeter.

**Solution**

*One way the design could be broken into rectangles, squares, and triangles is shown below. Students should measure each segment to the nearest millimeter and then use the appropriate formula to calculate the area of each shape. Once all the shape areas are found, the total area can be found by adding up the individual areas. Challenge students to record in their journals an explanation of the process used to calculate the area. In the example shown, the shape was separated into triangles, and rectangles. The total area is 13,262 mm<sup>2</sup>.*

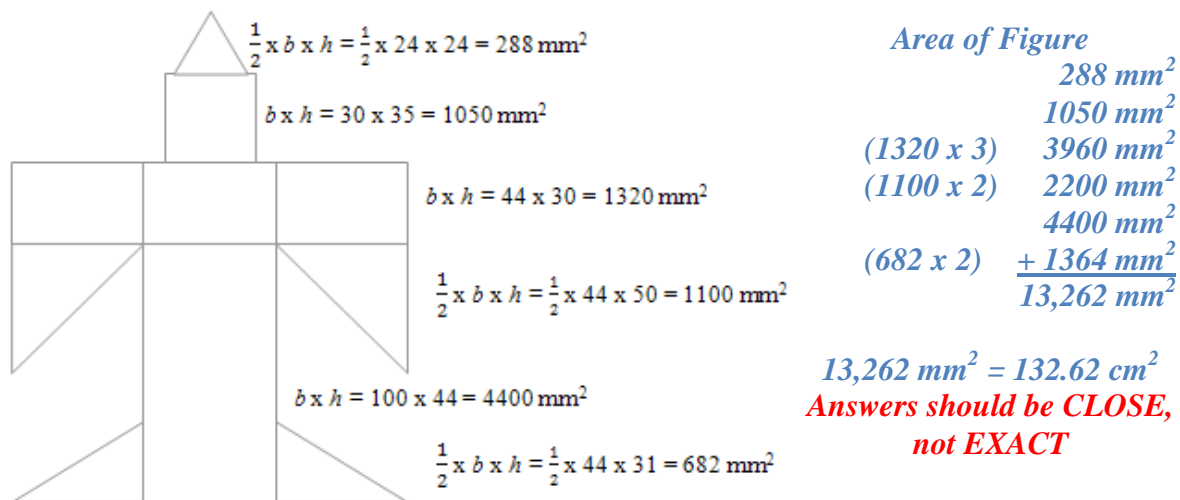

*Students can be asked to find the area of the figure using square centimeters. In this case, students could measure to the nearest tenth of a centimeter. For example, the top triangle would have dimensions of 2.4cm x 2.4 cm and have an area of 2.88 cm<sup>2</sup>. Ask students to include measurements of the dimensions of each shape – that way, areas found within the range of the given solution can be verified and accepted.*

**Questions/Prompts for Formative Student Assessment**

- Do you see any rectangles or triangles that could be contained within this figure?
- If you don't have a formula for area, how can you determine the area of a figure?
- How do you find the area of a triangle? Rectangle? Parallelogram? Square?
- What is the base of this shape? What is the height of this shape? How do you know this is the height of the shape? (How is the height related to the base?)

**Questions for Teacher Reflection**

- Which students were able to divide the figure into shapes for which they could find the area?
- Which students were able to use the formulae correctly to find the area of the shapes?
- Do students understand that the base and the height must be perpendicular?

## **DIFFERENTIATION**

### **Extension**

Have students design their own shape made up of squares, rectangles, parallelograms, and triangles. After they find the total area of their design, they can challenge a partner to find the area of their design.

### **Intervention**

Provide cutouts of the individual shapes for students to manipulate. Calculate the areas and write it on the cut-outs. Then allow students to combine the areas of each figure.

## **TECHNOLOGY CONNECTIONS**

- <http://illuminations.nctm.org/LessonDetail.aspx?ID=L583> This web site provides a lesson for finding the area of irregular figures.
- <http://illuminations.nctm.org/LessonDetail.aspx?ID=U160> The lesson above is part of this unit on finding area.
- <http://www.shodor.org/interactivate/lessons/Area/> Lesson to accompany an imbedded applet <http://www.shodor.org/interactivate/activities/AreaExplorer/> This applet allows students to see the square units within the figure.

Name \_\_\_\_\_ Date \_\_\_\_\_

### What's My Area?

Find the area of this figure in square millimeters. Measure each segment to the nearest millimeter.

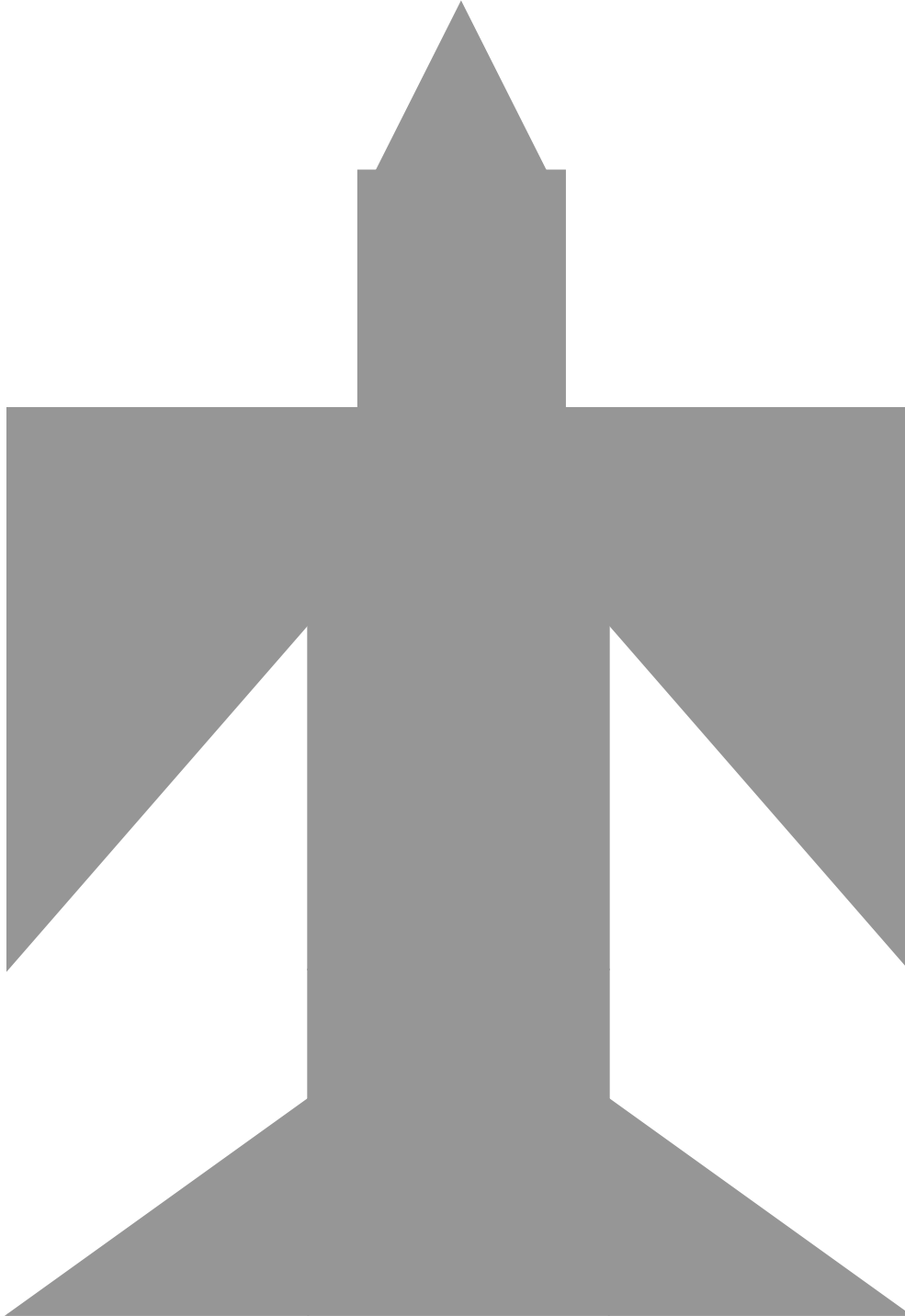

## **\*\*King Arthur's New Table**

[Back to Task Table](#)

*In this task, students to solve a problem by finding the area of squares, rectangles, parallelograms, and triangles using formulas.*

### **STANDARDS FOR MATHEMATICAL CONTENT**

**MGSE6.G.1 Find area of right triangles, other triangles, quadrilaterals, and polygons by composing into rectangles or decomposing into triangles and other shapes; apply these techniques in the context of solving real-world and mathematical problems.**

### **STANDARDS FOR MATHEMATICAL PRACTICE**

- 1. Make sense of problems and persevere in solving them.** Given an irregular two dimensional figure the student will compose and decompose to find the area.
- 2. Reason abstractly and quantitatively** – Students will use their understanding of polygons in solving with area. Students will be able to see and justify the reasoning for decomposing and composing an irregular polygon to solve for area.
- 3. Construct viable arguments and critique the reasoning of others.** Students will be able to review solutions to justify (verbally and written) why the solutions are reasonable.
- 4. Model with mathematics.** Students will use hands on/virtual manipulatives.
- 5. Use appropriate tools strategically.** Students will use a ruler, graph paper two-dimensional shapes to solve for area.
- 6. Attend to precision.** Students will use appropriate measurement units (square units vs. cubic units) and correct terminology to justify reasonable solutions.
- 7. Look for and make use of structure.** Students also decompose two-dimensional figures to find areas.
- 8. Look for and express regularity in repeated reasoning.** Students will explain why the formula or process is used to solve given problems.

### **ESSENTIAL QUESTIONS**

- How can we use one figure to determine the area of another?
- How can shapes be composed and decomposed to create new shapes?
- How are the areas of geometric figures related to each other?
- How can the formulas for the area of plane figures be used to solve problems?

### **MATERIALS**

- *Sir Cumference and the First Round Table* by Cindy Neuschwander or similar book about plane figures
- [1 cm dot grid paper](#) (optional)
- Geoboard and rubber bands (optional)
- Pattern Blocks (optional)



### **TASK COMMENTS**

One way to introduce this task is by reading *Sir Cumference and the First Round Table* by Cindy Neuschwander or a similar book about plane figures. As the book is read, students may cut a piece of 1 cm grid paper as a “table” and follow Sir Cumference’s and Lady Di’s steps to modify their “tables.” Discuss with students whether or not the area changes as the table is transformed. Allow the students to use manipulatives such as a Geoboard or Pattern Blocks to explore the figure and find area.

### **BACKGROUND KNOWLEDGE**

Students should build on their understanding of area from the learning task, “Who Put the Tang in Tangram?” to find the areas required in this task.

If King Arthur’s meeting room is 20 m  $\times$  12 m, what would be a perfect shape and size for the table in his meeting room? The table must seat all twelve knights and leave least 3 meters of space between the table and the wall for the knights to walk and each knight will need approximately 1.5 meters of linear space (**not area**) at the table. Use the grid paper to sketch each table and the charts below to record the information for each table your group considers creating for the knights.

### **Questions/Prompts for Formative Student Assessment**

- How are parallelograms and rectangles alike?
- Is there anything I can do to make a parallelogram look like a rectangle without changing the area?
- Is there anything I can do to make a rectangle look like a parallelogram without changing the area?
- How are triangles and rectangles alike?
- How is the area of a triangle related to the area of a rectangle?
- How are triangles and parallelograms alike?
- How is the area of a triangle related to the area of a parallelogram?
- How much space does each table require? (What’s its area?)
- How can you use a formula to find the area of each shape?
- Which shape is the best one to use to make a table for the room? Why do you think so?
- Did you meet the requirement for space to walk around the table? How do you know?
- Does each knight have at least 1.5 meters of space at the table? How do you know?
- Why did you choose the table you did for the knights?

### **Questions for Teacher Reflection**

- Were students able to find the area of all table shapes?
- Did students choose a table for the room and defend their choice using mathematical reasoning?
- Which students are able to explain how to derive the formula for the area of a rectangle, square, parallelogram, and triangle?

## DIFFERENTIATION

### Extension

Change the size of the room and/or the number of knights.

### Intervention

Allow students to focus on just the square and rectangle first. Students may choose to work with 1-inch square tiles. Then have students move onto the parallelogram and triangle. Students may find it easier to work with [1 cm dot grid paper](#) instead of the grid paper provided.

## TECHNOLOGY CONNECTIONS

- [http://www.geogebra.org/en/wiki/index.php/Area\\_Formulae](http://www.geogebra.org/en/wiki/index.php/Area_Formulae) Several interactive applets for exploring the formulae for rectangles, triangles, and parallelograms.
- <http://illuminations.nctm.org/ActivityDetail.aspx?ID=108> Area tool allows students to explore the area of triangles and parallelograms.

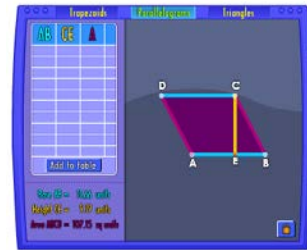
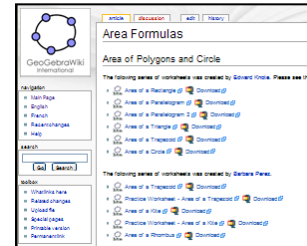

### Reminder

It is important to **use base times height** for the formula for the area of a rectangle or square instead of length times width ( $l \times w$ ) or side times side ( $s^2$ ) so that students will be able to make the connection to the formulas for parallelograms and triangles.

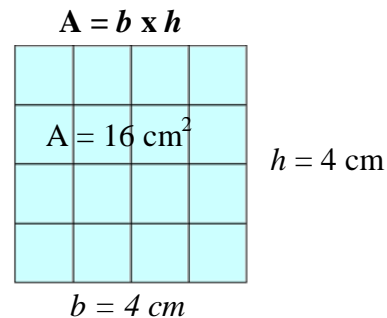
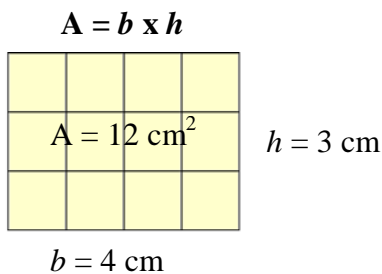

If students know the formula for finding the area of squares and rectangles, they can use this knowledge to find the formula for parallelograms and triangles.

A rectangle can be turned into a parallelogram by cutting off a triangle and sliding it to the opposite side as shown below. Since a parallelogram can be created from a rectangle without changing the area, the formula for the area of a parallelogram is the same as the formula for the area of a rectangle,  $A = b \times h$ .

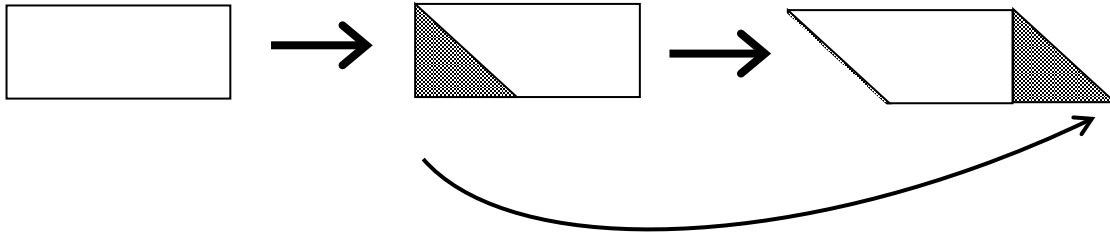

A parallelogram can be turned into a rectangle by cutting off a triangle and sliding it to the opposite side as shown below. Since a parallelogram can be rearranged into a rectangle without changing the area, the formula for the area of a parallelogram is the same as the formula for the area of a rectangle,  $A = b \times h$ .

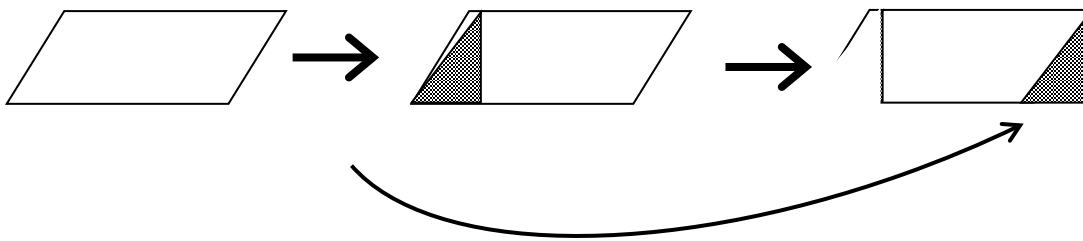

A triangle can be formed by drawing a diagonal in a rectangle. Because two congruent triangles are formed, a triangle is  $\frac{1}{2}$  of a rectangle. Therefore, the formula for finding the area of a triangle would be  $\frac{1}{2}$  the formula for the area of a rectangle,  $A = \frac{1}{2}(b \times h)$  or  $A = \frac{b \times h}{2}$ .

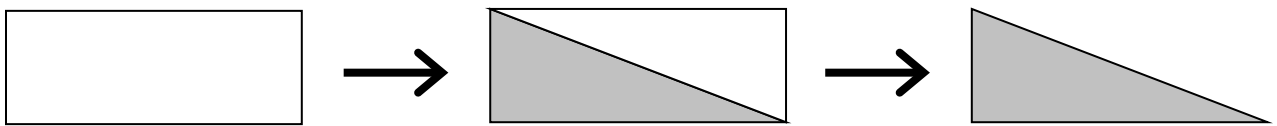

Also, a triangle can be formed by drawing a diagonal in a parallelogram. If you draw a diagonal in the parallelogram, you get two congruent triangles. So, a triangle is  $\frac{1}{2}$  of a parallelogram. And, the formula for finding the area of a triangle would be  $\frac{1}{2}$  the formula for the area of a parallelogram,  $A = \frac{1}{2}(b \times h)$ .



Name \_\_\_\_\_ Date \_\_\_\_\_

### King Arthur's New Table

**If King Arthur's meeting room is 20 m × 12 m, what would be a perfect shape and size for the table in his meeting room?**

The table must seat all 12 knights and leave **at** least 3 m of space between the table and the wall for the knights to walk and each knight will need approximately 1.5 meters of **linear** space at the table. Use the grid paper to sketch each table and the charts below to record the information for each table your group considers creating for the knights.

Table Shape: Rectangle

Table Shape: Square

Formula: \_\_\_\_\_

Formula: \_\_\_\_\_

Table Number	Base	Height	Area
1			
2			
3			
4			
5			

Table Number	Base	Height	Area
1			
2			
3			
4			
5			

Table Shape: Parallelogram

Table Shape: Triangle

Formula: \_\_\_\_\_

Formula: \_\_\_\_\_

Table Number	Base	Height	Area
1			
2			
3			
4			
5			

Table Number	Base	Height	Area
1			
2			
3			
4			
5			





## **Formative Assessment Lesson: Area of Composite Figures**

*Source: Georgia Mathematics Design Collaborative*

This lesson is intended to help you assess how well students are able to:

- Apply the properties of various regular and irregular polygons
- Compose and decompose regular and irregular polygons using rectangles and/or triangles
- Apply formulas to find areas of regular and irregular polygons
- Solve real-world and mathematical problems involving area

### **STANDARDS ADDRESSED IN THIS TASK:**

**MGSE6.G.1 Find area of right triangles, other triangles, quadrilaterals, and polygons by composing into rectangles or decomposing into triangles and other shapes; apply these techniques in the context of solving real-world and mathematical problems.**

### **STANDARDS FOR MATHEMATICAL PRACTICE:**

This lesson uses all of the practices with emphasis on:

1. Make sense of problems and persevere in solving them
3. Construct viable arguments and critique the reasoning of others

### **TASK DESCRIPTION, DEVELOPMENT AND DISCUSSION:**

Tasks and lessons from the Georgia Mathematics Design Collaborative are specifically designed to help teachers effectively formatively assess their students. The way the tasks and lessons are designed gives the teacher a clear understanding of what the students are able to do and not do. Within the lesson, teachers will find suggestions and question prompts that will help guide students towards understanding.

The task, *Area of Composite Figures*, is a Formative Assessment Lesson (FAL) that can be found at: <http://ccgpsmathematics6-8.wikispaces.com/Georgia+Mathematics+Design+Collaborative+Formative+Assessment+Lessons>

**\*\*Finding Surface Area**

[Back to Task Table](#)

*In this task, students will identify 2-D nets and 3-D figures and calculate surface area using nets and formulas.*

**STANDARDS FOR MATHEMATICAL CONTENT**

**MGSE6.G.4** Represent three-dimensional figures using nets made up of rectangles and triangles, and use the nets to find the surface area of these figures. Apply these techniques in the context of solving real-world and mathematical problems.

**STANDARDS FOR MATHEMATICAL PRACTICE**

- 1. Make sense of problems and persevere in solving them.** Given a rectangular prisms, rectangular pyramids, triangular prisms, and triangular prisms students will find surface area using the net.
- 2. Reason abstractly and quantitatively** – Students will use draw nets for prisms and pyramids when given the given the figure. Students will be able to see and justify the reasoning for decomposing and composing triangles and rectangles to solve for surface area. Students will use the relationships between two-dimensional and three-dimensional shapes to understand surface area.
- 3. Construct viable arguments and critique the reasoning of others.** Students will justify how they found surface. Students will review solutions and justify (verbally and written) why the solutions are reasonable.
- 4. Model with mathematics.** Students will sketch nets for three-dimensional shapes.
- 6. Attend to precision.** Students will use appropriate measurement units and correct terminology to justify reasonable solutions.
- 7. Look for and make use of structure.** Students will understand the relationship between the structure of a three-dimensional shape and the net and the surface area.

**ESSENTIAL QUESTIONS**

- How can I use manipulatives and nets to help compute the surface areas of rectangular and triangular prisms?

**TEACHER NOTES**

**Items #4 and #8 include improved graphics.**

Answers

<i>1. 56 cm<sup>2</sup></i>	<i>2. 82 mm<sup>2</sup></i>	<i>3. 94 mm<sup>2</sup></i>	<i>4. 120 cm<sup>2</sup></i>	<i>5. answers will vary</i>
<i>6. 244 in<sup>2</sup></i>	<i>7. 280 cm<sup>2</sup></i>	<i>8. 180 cm<sup>2</sup></i>	<i>9. 95 mm<sup>2</sup></i>	<i>10. 459 in<sup>2</sup></i>



Name \_\_\_\_\_

**Finding Surface Area**

Write the name of each figure and find the surface area of the nets drawn below.

1.

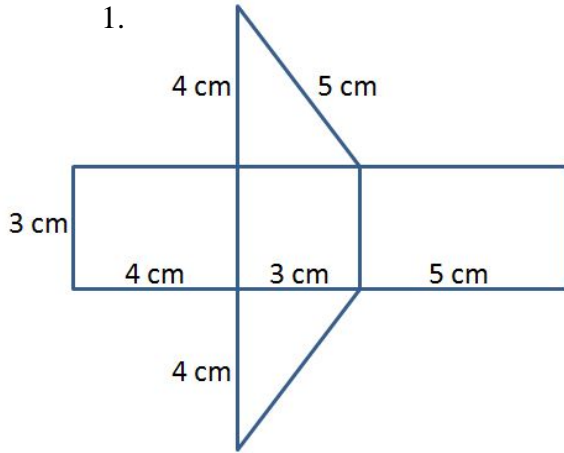

Name \_\_\_\_\_ Surface Area \_\_\_\_\_

2.

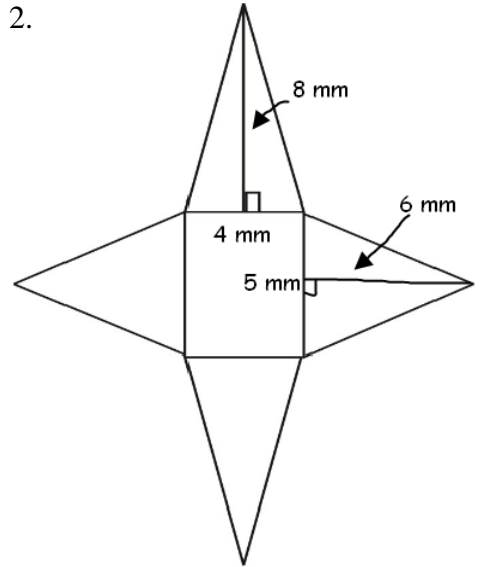

Name \_\_\_\_\_ Surface Area \_\_\_\_\_

3.

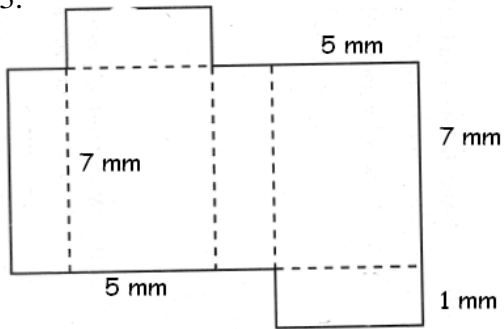

Name \_\_\_\_\_ Surface Area \_\_\_\_\_

4.

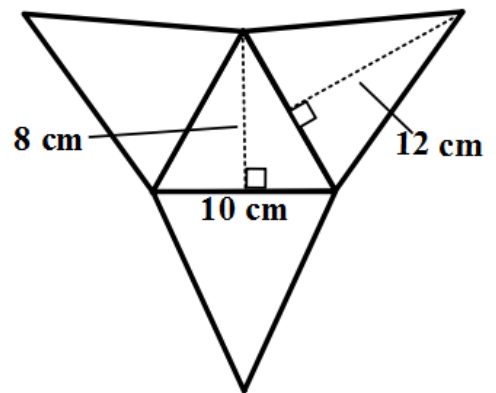

Name \_\_\_\_\_ Surface Area \_\_\_\_\_

5. Choose ONE of the nets above and write a constructed response that explains the steps used to calculate the surface area of the figure.

**For 6-10, name each figure, draw the NET, and find the surface area.**

Name each figure and the surface area of each figure.

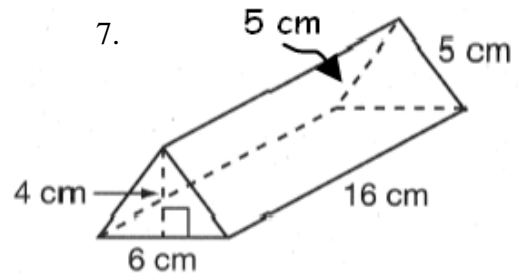
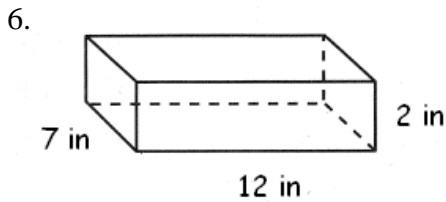

Name \_\_\_\_\_ Surface Area \_\_\_\_\_

Name \_\_\_\_\_ Surface Area \_\_\_\_\_

8.

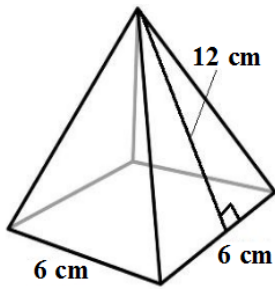

Name \_\_\_\_\_ Surface Area \_\_\_\_\_

9.

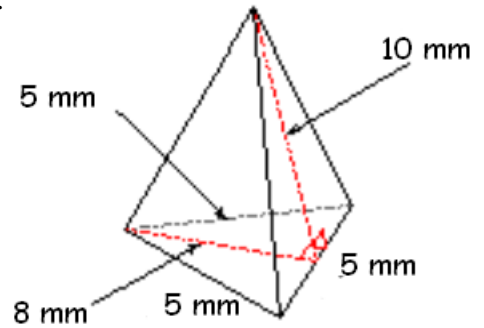

Name \_\_\_\_\_ Surface Area \_\_\_\_\_

10.

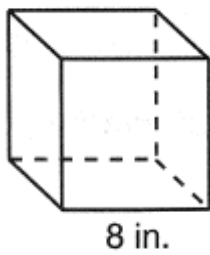

Name \_\_\_\_\_ Surface Area \_\_\_\_\_

## **\*\*How Many Ways?**

[Back to Task Table](#)

*In this task, students will use 24 sugar cubes to build cubes and rectangular prisms in order to generalize a formula for the volume of rectangular prisms.*

### **STANDARDS FOR MATHEMATICAL CONTENT**

**MGSE6.G.2 Find the volume of a right rectangular prism with fractional edge lengths by packing it with unit cubes of the appropriate unit fraction edge lengths ( $\frac{1}{2}$  u), and show that the volume is the same as would be found by multiplying the edge lengths of the prism. Apply the formulas  $V = (\text{length}) \times (\text{width}) \times (\text{height})$  and  $V = (\text{area of base}) \times (\text{height})$  to find volumes of right rectangular prisms with fractional edge lengths in the context of solving real-world and mathematical problems.**

### **STANDARDS FOR MATHEMATIC PRACTICE**

**1. Make sense of problems and persevere in solving them.** Given a right rectangular prism a student will solve for the volume.

**3. Construct viable arguments and critique the reasoning of others.** Students will be able to review solutions to justify (verbally and written) why the solutions are reasonable.

**4. Model with mathematics.** Use hands on/virtual manipulatives (cubes) to find volume of rectangular prisms.

**5. Use appropriate tools strategically.** Students will use a ruler, graph paper two-dimensional and three-dimensional shapes to solve for area, volume and surface area. In addition, students will determine appropriate area formulas to use for given situations.

**6. Attend to precision.** Students will use appropriate measurement units (square units vs. cubic units) and correct terminology to justify reasonable solutions.

**8. Look for and express regularity in repeated reasoning.** Students will explain why the formula or process is used to solve given problems. Students use properties of figures and properties of operations to connect formula to volume.

### **ESSENTIAL QUESTIONS**

- **In what ways can I measure the volume of a rectangular prism with fractional edge lengths?**
- How can I determine the appropriate units of measure that should be used when computing the volumes of a rectangular prism?
- Why can different rectangular prisms have the same volume?

### **MATERIALS**

- “How Many Ways?” student recording sheet
- Snap Cubes or 1” cubes
- *optional:* Sugar Cubes ( $\frac{1}{2}$ ” variety)

### **TASK COMMENTS**

To introduce this task, ask students to make a cube and a rectangular prism using snap cubes. Discuss the attributes of cubes and rectangular prisms – faces, edges, and vertices. Initiate a conversation about the figures:

- What is the shape of the cube’s base?
- What is the shape of the rectangular prism’s base? The base of each is a rectangle (remember a square is a rectangle!).

Students should notice that the cube and rectangular prism are made up of repeated layers of the base. Describe the base of the figure as the first floor of a rectangular-prism-shaped building. Ask students, “What is the area of the base? Next, discuss the height of the figure. Ask students, “How many layers high is the cube?” or “How many layers high is the prism?” The number of layers will represent the height. **DO NOT LEAD THE DISCUSSION TO THE VOLUME FORMULA.** Students will use the results of this task to determine the volume formula for rectangular prisms on their own.

While working on the task, students do not need to fill in all ten rows of the “How Many Ways?” student recording sheet. Some students may recognize that there are only six different ways to create a rectangular prism using 24 snap cubes. For students who have found four or five ways to build a rectangular prism, tell them they have not found all of the possible ways without telling them exactly how many ways are possible. It is important for students to recognize when they have found all possible ways and to prove that they have found all of the possible rectangular prisms.

Once students have completed the task, lead a class discussion about the similarities and differences between the rectangular prisms they created using 24 snap cubes. Allow students to explain what they think about finding the volume of each prism they created. Also, allow students to share their conjectures about an efficient method to find the volume of any rectangular prism. Finally, as a class, come to a consensus regarding an efficient method for finding the volume of a rectangular prism.

### **Background Knowledge**

The “How Many Ways?” student recording sheet asks students to determine the area of the base of each prism using the measurements of base and height of the solid’s BASE. The general formula for the area of a parallelogram (as discussed in the task on deriving formulas) is  $A = bh$ . Knowing the general formula for the area of a parallelogram enables students to memorize ONE formula for the area of rectangles, squares, and parallelograms since each of these shapes is a parallelogram.

The general formula for the volume of a prism is  $V = bh$ , (also written as  $V = Bh$ ) where  $b$  (or  $B$ ) is the area of the BASE of the prism and  $h$  is the height of the prism. Knowing the general formula for the volume of a prism prevents students from having to memorize different formulas for each of the types of prisms they encounter.

There are six possible rectangular prisms that can be made from 24 snap cubes.

$1 \times 1 \times 24$      $1 \times 2 \times 12$      $1 \times 3 \times 8$      $1 \times 4 \times 6$      $2 \times 2 \times 6$      $2 \times 3 \times 4$

Students may identify rectangular prisms with the same dimensions in a different order, for example,  $1 \times 4 \times 6$ ,  $1 \times 6 \times 4$ ,  $6 \times 1 \times 4$ ,  $6 \times 4 \times 1$ ,  $4 \times 1 \times 6$ ,  $4 \times 6 \times 1$ . All of these are the same rectangular prism, just oriented differently. It is okay for students to include these different orientations on their recording sheet. However, some students may need to be encouraged to find different rectangular prisms.

**When building the prisms with sugar cubes (or other cubes), you may wish to allow students to fill in Tables 1 and 2 simultaneously so that they are better able to see mathematical relationships between the two tables, and less likely to mix up the corresponding measurements.**

**Questions/Prompts for Formative Student Assessment**

- What is the shape of the rectangular prism’s base? How can you find the area of the base?
- What is the height of the rectangular prism? How do you know? (How many layers or “floors” does it have?)
- What is the volume of the rectangular prism? How do you know? (How many snap cubes did you use to make the rectangular prism? How do you know?)

**Questions for Teacher Reflection**

- Which students are able to discuss how cubes are also rectangular prisms?
- Which students are able to build different rectangular prisms using 24 cubes?
- Which students are able to discover the formula for the volume of rectangular prisms?

Answers

2. Shape #	Bottom Layer			Number of Layers of the Base (Height of Solid)	Volume (number of sugar cubes)
	length	width	Area of the BASE (bottom layer)		
1	1	24	24 cubes	1	24
2	1	12	12 cubes	2	24
3	1	8	8 cubes	3	24
4	1	6	6 cubes	4	24
5	2	6	12 cubes	2	24
6	3	4	12 cubes	2	24
7					
8					
9					
10					

*As mentioned in the Background Knowledge section, student answers may vary due to different orientations (although, if using sugar cubes or non-connecting cubes, prisms with smaller heights will be easier to build.)*

3. What do you notice about the rectangular prisms you created?

*They all used 24 cubes, but they have different dimensions. The number of cubes in the bottom layer can be multiplied by the number of layers to determine the number of cubes.*

4. How can you find the volume without building and counting the cubes?

*Multiply the number of cubes in the bottom layer (area of the base) by the number of layers (height).*

5. Each cube is  $\frac{1}{2}'' \times \frac{1}{2}'' \times \frac{1}{2}''$ . What is the volume of each cube in cubic inches?

*The volume of each cube is  $\frac{1}{8}$  cubic inch.*

6.

Shape #	Bottom Layer			Height of Solid (inches)	Volume (cubic inches)
	length (inches)	width (inches)	Area of the BASE (A = lw)		
1	$\frac{1}{2}$	12	$6 \text{ in.}^2$	$\frac{1}{2} \text{ inch}$	$3 \text{ in.}^3$
2	$\frac{1}{2}$	6	$3 \text{ in.}^2$	1 inch	$3 \text{ in.}^3$
3	$\frac{1}{2}$	4	$2 \text{ in.}^2$	1.5 inches	$3 \text{ in.}^3$
4	$\frac{1}{2}$	3	$1.5 \text{ in.}^2$	2 inches	$3 \text{ in.}^3$
5	1	3	$3 \text{ in.}^2$	1 inch	$3 \text{ in.}^3$
6	1.5	2	$3 \text{ in.}^2$	1 inch	$3 \text{ in.}^3$
7					
8					
9					
10					

7. What do you notice about the volumes of the rectangular prisms you created?

*Each volume is the same: 3 cubic inches.*

**8. Look at the two tables you completed. What mathematical relationships do you notice between the dimensions of the corresponding shapes in each table?**

*In the 2<sup>nd</sup> table, the length, width, and height of each shape is half of the respective dimensions in the 1<sup>st</sup> table; the area of the base is one-fourth of the area of each prism in the 1<sup>st</sup> table; and the volume of each prism is one-eighth of the volume in the 1<sup>st</sup> table.*

## DIFFERENTIATION

### Extension

- Ask students to suggest possible dimensions for a rectangular prism that has a volume of  $42 \text{ cm}^3$  without using snap cubes.
- Ask students to explore the similarities and differences of a rectangular prism with dimensions 3 cm x 4 cm x 5 cm and a rectangular prism with dimensions 5 cm x 3 cm x 4 cm. Students can consider the attributes and volumes of each of the prisms.

- Students can calculate the area of each surface of the solid and determine the total surface area.
- **Students can explore what happens to the surface area and volume of rectangular prisms as you double or halve each (or only 1 or 2) of the dimensions by creating their own prisms and then manipulating the dimensions. Be sure to encourage students to predict how changing the dimensions will affect the surface area/volume BEFORE calculating.**

### **Intervention**

- Some students may need organizational support from a peer or by working in a small group with an adult. This person may help students recognize duplications in their table as well as help them recognize patterns that become evident in the table.
- Some students may benefit from using the “Cubes” applet on the Illuminations web site (see link in “Technology Connection” below). It allows students to easily manipulate the size of the rectangular prism and then build the rectangular prism using unit cubes.

### **TECHNOLOGY CONNECTIONS**

- <http://illuminations.nctm.org/ActivityDetail.aspx?ID=6> The activity is called “Cubes.” Students are able to select the dimensions of a cube and then fill it with cubic units.



Name \_\_\_\_\_ Date \_\_\_\_\_

## How Many Ways?

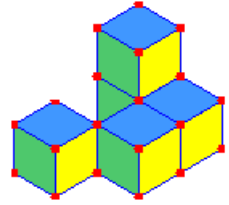

1. Count out 24 **sugar** cubes.
2. Build all the rectangular prisms that can be made with the 24 **sugar** cubes. For each rectangular prism, record the dimensions and volume in the table below.
3. What do you notice about the rectangular prisms you created?
4. How can you find the volume without building and counting the cubes?

Shape #	Bottom Layer			Number of Layers of the Base (Height of Solid)	Volume ( <b>number of sugar cubes</b> )
	length	width	Area of the BASE (bottom layer)		
1					
2					
3					
4					
5					
6					
7					
8					
9					
10					

Now that we have found the volume in terms of number of **sugar** cubes, let's find the volume of your shapes in terms of cubic inches.

5. Each **sugar** cube is  $\frac{1}{2}'' \times \frac{1}{2}'' \times \frac{1}{2}''$ . What is the volume of each **sugar** cube in cubic inches?
6. Fill out the table using the measurement of each edge of your rectangular prisms. **Make sure that each shape in the table below matches up with the corresponding shapes in the table on the previous page.**
7. What do you notice about the volumes of the rectangular prisms you created?
- 8. Look at the two tables you completed. What mathematical relationships do you notice between the dimensions of the corresponding shapes in each table?**

Shape #	Bottom Layer			Height of Solid (inches)	Volume (cubic inches)
	length (inches)	width (inches)	Area of the BASE ( $A = lw$ )		
1					
2					
3					
4					
5					
6					
7					
8					
9					
10					

## **Banana Bread**

[Back to Task Table](#)

Adapted from Illustrative Mathematics

*In this task, students will solve a multi-step problem involving a rectangular prism with non-integer edge lengths.*

### **STANDARDS FOR MATHEMATICAL CONTENT**

**MGSE6.G.2 Find the volume of a right rectangular prism with fractional edge lengths by packing it with unit cubes of the appropriate unit fraction edge lengths ( $\frac{1}{2}$  u), and show that the volume is the same as would be found by multiplying the edge lengths of the prism. Apply the formulas  $V = (\text{length}) \times (\text{width}) \times (\text{height})$  and  $V = (\text{area of base}) \times (\text{height})$  to find volumes of right rectangular prisms with fractional edge lengths in the context of solving real-world and mathematical problems.**

### **STANDARDS FOR MATHEMATIC PRACTICE**

- 1. Make sense of problems and persevere in solving them.** Given a right rectangular prism a student will solve for the volume.
- 3. Construct viable arguments and critique the reasoning of others.** Students will be able to review solutions to justify (verbally and written) why the solutions are reasonable.
- 4. Model with mathematics.** Use hands on/virtual manipulatives (cubes) to find volume of rectangular prisms.
- 5. Use appropriate tools strategically.** Students will use a ruler, graph paper two-dimensional and three-dimensional shapes to solve for area, volume and surface area. In addition, students will determine appropriate area formulas to use for given situations.
- 6. Attend to precision.** Students will use appropriate measurement units (square units vs. cubic units) and correct terminology to justify reasonable solutions.
- 8. Look for and express regularity in repeated reasoning.** Students will explain why the formula or process is used to solve given problems. Students use properties of figures and properties of operations to connect formula to volume.

### **ESSENTIAL QUESTIONS**

- How can I compare the volumes of two rectangular prisms?
- How does the fractional edge length affect the volume of a prism?
- How can I estimate comparisons of volumes for prisms with fractional edge lengths?

### **TEACHER NOTES**

The purpose of this task is two-fold. One is to provide students with a multi-step problem involving volume. The other is to give them a chance to discuss the difference between exact calculations and their meaning in a context. It is important to note that students could argue that whether the new pan is appropriate depends in part on the accuracy of Leo's estimate for the needed height.

Leo's recipe for banana bread won't fit in his favorite pan. The batter fills the 8.5-inch by 11-inch by 1.75 inch pan to the very top, but when it bakes it spills over the side. He has another pan that is 9 inches by 9 inches by 3 inches, and from past experience, he thinks he needs about an inch between the top of the batter and the rim of the pan. Should he use this pan?



**Solution:**

*In order to find out how high the batter will be in the second pan, we must first find out the total volume of the batter that the recipe makes. We know that the recipe fills a pan that is 8.5 inches by 11 inches by 1.75 inches. We can calculate the volume of the batter multiplying the length, the width, and the height:*

$$V = 8.5 \text{ in} \times 11 \text{ in} \times 1.75 \text{ in}$$

$$V = 163.625 \text{ in}^3$$

*We know that the batter will have the same volume when we pour it into the new pan. When the batter is poured into the new pan, we know that the volume will be  $9 \times 9 \times h$  where  $h$  is the height of the batter in the pan. We already know that  $V = 163.625 \text{ in}^3$ , so:*

$$V = l \times w \times h$$

$$163.625 \text{ in}^3 = 9 \text{ in} \times 9 \text{ in} \times h$$

$$163.625 \text{ in}^3 = 81 \text{ in}^2 \times h$$

$$163.625 \text{ in}^3 / 81 \text{ in}^2 = h$$

$$2.02 \text{ in.} \approx h$$

*Therefore, the batter will fill the second pan about 2 inches high. Since the pan is 3 inches high, there is nearly an inch between the top of the batter and the rim of the pan, so it will probably work for the banana bread (assuming that Leo is right that that an inch of space is enough).*

## **Banana Bread**

Name \_\_\_\_\_ Date \_\_\_\_\_

Leo's recipe for banana bread won't fit in his favorite pan. The batter fills the 8.5-inch by 11-inch by 1.75 inch pan to the very top, but when it bakes it spills over the side. He has another pan that is 9 inches by 9 inches by 3 inches, and from past experience he thinks he needs about an inch between the top of the batter and the rim of the pan. Should he use this pan?



## **\*\*Volume and Cubes**

[Back to Task Table](#)

*In this problem-based task, students will examine the mathematical relationship between the volume of a rectangular prism in cubic units and the number of unit cubes with fractional edge lengths (i.e.,  $\frac{1}{2}$ -inch) it takes to fill the prism.*

### **STANDARDS FOR MATHEMATICAL CONTENT**

**MGSE6.G.2 Find the volume of a right rectangular prism with fractional edge lengths by packing it with unit cubes of the appropriate unit fraction edge lengths ( $\frac{1}{2}$  u), and show that the volume is the same as would be found by multiplying the edge lengths of the prism. Apply the formulas  $V = (\text{length}) \times (\text{width}) \times (\text{height})$  and  $V = (\text{area of base}) \times (\text{height})$  to find volumes of right rectangular prisms with fractional edge lengths in the context of solving real-world and mathematical problems.**

### **STANDARDS FOR MATHEMATICAL PRACTICE**

- 1. Make sense of problems and persevere in solving them.** Students will solve problems by finding the volume of rectangular prisms with fractional edges.
- 2. Reason abstractly and quantitatively** – Students will use their understanding of the volume to find the number of cubes that will fit inside a rectangular prism. Students will be able to see and justify the reasoning packing a rectangular prism to find volume.
- 6. Attend to precision.** Students will use appropriate measurement units (square units and cubic units) and correct terminology to justify reasonable solutions.
- 7. Look for and make use of structure.** Students will understand the relationship between the structure of a three-dimensional shape and its volume formula
- 8. Look for and express regularity in repeated reasoning.** Students use properties of figures and properties of operations to connect formulas to volume.

### **ESSENTIAL QUESTIONS**

- What happens to the number of cubes that will fit into a rectangular prisms change when the sizes of the cubes change?
- How can I determine the appropriate units of measure that should be used when computing the volumes of a right rectangular prism?
- **In what ways can I measure the volume of a rectangular prism with fractional edge lengths?**

### **TEACHER NOTES**

**You may wish to have students create a net for a rectangular prism that is 2 in. by  $1\frac{1}{2}$  in. by 4 in. and try to fill it with 12 one-cubic-inch cubes. This will help reveal a meaningful context for examining the volume of rectangular prisms with fractional edge lengths.**

## **\*\*Volume and Cubes**

### **Part 1**

The company Domino produces boxes that are 2 in. by 1½ in. by 4 in. The sugar cubes used to fill the box are 1 inch on each side.

- 1. What is the volume, in cubic inches, of the Domino box?**  
*12 cubic inches*
- 2. Look at your answer for #1. Is it possible for Domino to put 12 sugar cubes in each box?**  
*No. Only 8 sugar cubes would fit, because one of the dimensions is 1½ inches, and a 1-cubic-inch sugar cube will not fit into a ½-inch-wide space.*
- 3. Domino recently decided to decrease the size of the sugar cubes and make them ½ in. on all sides. Jeremy thinks that since the sugar cubes are twice as small, so the box should fit twice as many cubes. Do you agree or disagree? Explain.**  
*Jeremy is incorrect because more than one dimension of the sugar cube was cut in half. The length, width, and height were each halved, so the sugar cubes were actually 1/8 of the original size.*
- 4. What is the volume of each sugar cube (now that each side is ½ inch long)?**  
 *$(\frac{1}{2} \times \frac{1}{2} \times \frac{1}{2}) = 1/8in.^3$*
- 5. How many ½-in. sugar cubes would it take to fill the Domino box?**  
 *$12 in.^3 \div 1/8in.^3 = 96$  cubes*  
**OR**  
 *$4 \times 3 \times 8 = 96$  half-inch sugar cubes*
- 6. The Domino Company packs 36 boxes in each case to ship to stores.**
  - a. You have been assigned the task to determine the least amount of volume required to hold 36 boxes. Explain how you arrived at your answer.**  
*The volume of each individual box is 12 cubic inches.  $12 \times 36 = 432$  cubic inches. The case needs to hold at least 432 in.<sup>3</sup>*
  - b. How many ½-in. sugar cubes would be in each case? Explain how you know.**  
*There are 96 sugar cubes in each Domino box. 36 boxes are packed inside each case. So,  $96 \times 36 = 3,456$  sugar cubes.*

Part 2

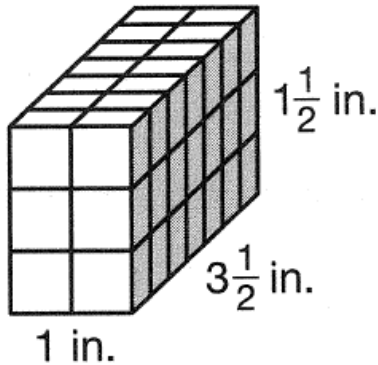

Use the rectangular prism above to answer questions 1-5.

1. How many cubes are there in the rectangular prism? **42 cubes**
2. What are the dimensions of the cubes used to build the rectangular prism?  
 **$\frac{1}{2}$  inch by  $\frac{1}{2}$  inch by  $\frac{1}{2}$  inch**
3. What is volume of each cube?  **$\frac{1}{8}$  in.<sup>3</sup>**
4. What is the volume of the rectangular prism?  **$5\frac{1}{4}$  in.<sup>3</sup>**
5. How is the volume of the rectangular prism related to the number of cubes and volume of cubes that fit into the rectangular prism?

***The volume of the rectangular prism is also the number of cubes multiplied by the volume of each cube.***

***42 times  $\frac{1}{8}$  in.<sup>3</sup> is equal to the volume of the prism ( $5\frac{1}{4}$  in.<sup>3</sup>)***



Part 3

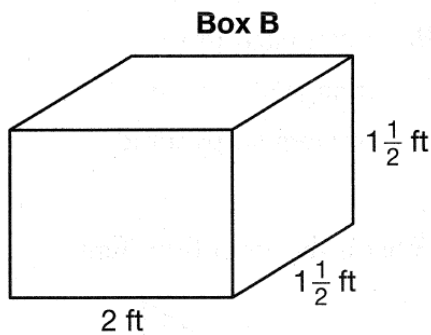

1. What is the volume of the rectangular prism above ?  $4.5 \text{ ft}^3$
2. Using cubes with side lengths of  $\frac{1}{2}$ -foot, how many cubes would fit inside the rectangular prism?  $(4)(3)(3) = 36 \text{ cubes}$
3. What is the volume of each cube in question 2 ?  $\frac{1}{8} \text{ ft}^3$
4. Multiply the number of cubes by the volume of each cube. EXPLAIN how this answer compares to the volume you calculated in number 1?  
 $(\frac{1}{8})(36) = 4.5 \text{ in}^3$
5. Using cubes with side lengths of  $\frac{1}{4}$  foot, how many cubes would fit inside this rectangular prism?  $(8)(6)(6) = 288 \text{ cubes}$
6. What is the volume of each cube?  $\frac{1}{64} \text{ ft}^3$
7. Multiply the number of cubes by the volume of each cube, and EXPLAIN how this answer compares to the volume you calculated in number 6? .  $(\frac{1}{64})(288) = 4.5 \text{ ft}^3$   
*Volume is the same each time,  $4.5 \text{ ft}^3$ . They number of cubes and size of cubes did not change the volume.*
8. Why does the number of cubes change but the volume stays the same? *The volume prism is fixed. The number of cubes depends upon the dimensions of the cube.*

Part 4

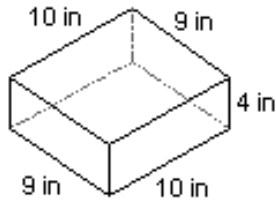

1. How many 1-in. cubes are needed to fill the bottom of the rectangular prism?  
 $(9)(10) = 90$  cubes
2. How many rows (**layers**) will be needed to fill the entire rectangular prism?  $4$  rows
3. How many  $\frac{1}{2}$ -in. cubes are needed to fill the bottom of the rectangular prism?  
 $(18)(20) = 360$  cubes
4. How many rows (**layers**) will be needed to fill the entire rectangular prism?  $8$  rows
5. How many  $\frac{1}{4}$ -in. cubes are needed to fill the bottom of the rectangular prism?  
 $(36)(40) = 1440$  cubes
6. How many rows (**layers**) will be needed to fill the entire rectangular prism?  $16$  rows
7. What relationship do you see between the size of the cube and the number of cubes needed to fill the rectangular prism?  
*As the size of the cubes increase the number of cubes needed to fill the rectangular prism decreases.*

Name \_\_\_\_\_

## Volume and Cubes

### Part 1

Domino produces boxes that are 2 in. by  $1\frac{1}{2}$  in. by 4 in. The sugar cubes used to fill the box are 1 inch on each side.

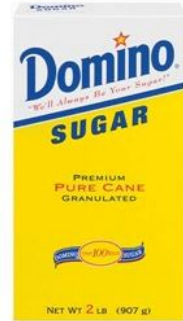

- 1. What is the volume, in cubic inches, of the Domino box?**
- 2. Look at your answer for #1. Is it possible for Domino to put 12 sugar cubes in each box?**
- 3. Domino recently decided to decrease the size of the sugar cubes and make them  $\frac{1}{2}$  in. on all sides. Jeremy thinks that since the sugar cubes are twice as small, so the box should fit twice as many cubes. Do you agree or disagree? Explain.**
- 4. What is the volume of each sugar cube (now that each side is  $\frac{1}{2}$  inch long)?**
5. How many  $\frac{1}{2}$ -in. sugar cubes would it take to fill the Domino box?
6. The Domino Company packs 36 boxes in each case to ship to stores.
  - a. You have been assigned the task to determine the least amount of volume required to hold 36 boxes. Explain how you arrived at your answer.**
  - b. How many  $\frac{1}{2}$ -in. sugar cubes would be in each case? Explain how you know.

**Part 2**

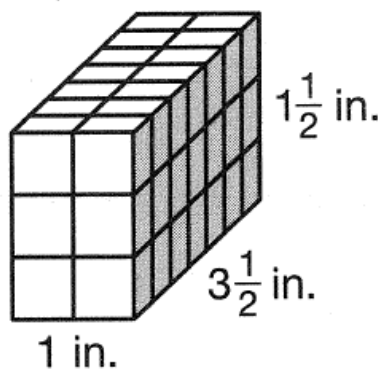

Use the rectangular prism above to answer questions 1-5.

1. How many cubes are there in the rectangular prism?
2. What are the dimensions of the cubes used to build the rectangular prism?
3. What is volume of each cube?
4. What is the volume of the rectangular prism?
5. How is the volume of the rectangular prism related to the number of cubes and volume of cubes that fit into the rectangular prism?

**Part 3**

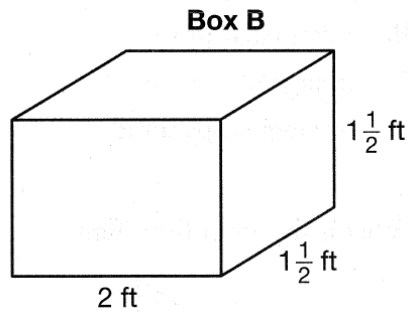

1. What is the volume of the rectangular prism above?
2. Using cubes with side lengths of  $\frac{1}{2}$  foot, how many cubes would fit inside the rectangular prism?
3. What is the volume of each cube in question 2?
4. Multiply the number of cubes by the volume of each cube. **EXPLAIN** how this answer compares to the volume you calculated in number 1?
5. Using cubes with side lengths of  $\frac{1}{4}$  foot, how many cubes would fit inside this rectangular prism?
6. What is the volume of each cube?
7. Multiply the number of cubes by the volume of each cube, **EXPLAIN** how this answer compares to the volume you calculated in number 6?
8. Why does number of cubes change but the volume stays the same?

**Part 4**

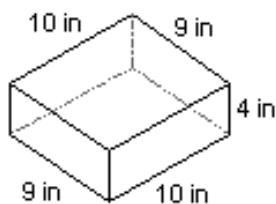

1. How many 1-in. cubes are needed to fill the bottom of the rectangular prism?
2. How many rows will be needed to fill the entire rectangular prism?
3. How many  $\frac{1}{2}$ -in. cubes are needed to fill the bottom of the rectangular prism?
4. How many rows will be needed to fill the entire rectangular prism?
5. How many  $\frac{1}{4}$ -in. cubes are needed to fill the bottom of the rectangular prism?
6. How many rows will be needed to fill the entire rectangular prism?
7. What relationship do you see between the size of the cube and the number of cubes needed to fill the rectangular prism?

## **Packaging our Goods – Rectangular Prisms (Spotlight Task)**

[Back to Task Table](#)

Task adapted from CCGPS Grade 6 Unit 5 task to “open up” student thinking.

*In this task, students will become an apprentice for Quality Track printing and prepare the packaging for graduation programs. The students will determine dimensions, the minimum amount of space needed and the square units to cover the box.*

### **STANDARDS FOR MATHEMATICAL CONTENT**

**MGSE6.G.2 Find the volume of a right rectangular prism with fractional edge lengths by packing it with unit cubes of the appropriate unit fraction edge lengths ( $\frac{1}{2}$  u), and show that the volume is the same as would be found by multiplying the edge lengths of the prism. Apply the formulas  $V = (\text{length}) \times (\text{width}) \times (\text{height})$  and  $V = (\text{area of base}) \times (\text{height})$  to find volumes of right rectangular prisms with fractional edge lengths in the context of solving real-world and mathematical problems.**

**MGSE6.G.4** Represent three-dimensional figures using nets made up of rectangles and triangles, and use the nets to find the surface area of these figures. Apply these techniques in the context of solving real-world and mathematical problems.

### **STANDARDS FOR MATHEMATICAL PRACTICE**

- 1. Make sense of problems and persevere in solving them.** Given a right rectangular prism a student will solve for the volume and surface area. Students will find surface area of triangular prism
- 2. Reason abstractly and quantitatively** – Students will use their understanding of volume to create the size of a box to ship a certain number of programs. Students will use the understanding of surface area to solve problems.
- 3. Construct viable arguments and critique the reasoning of others.** Students will be able to review solutions to justify (verbally and written) why the solutions are reasonable.
- 4. Model with mathematics.** Students will sketch the rectangular prisms.
- 6. Attend to precision.** Students will use appropriate measurement units (square units vs. cubic units).
- 7. Look for and make use of structure.** Students will understand the relationship between the structure of a three-dimensional shape and its volume formula and surface area.

### **ESSENTIAL QUESTIONS**

- How can I use manipulatives and nets to help compute the surface areas of rectangular and triangular prisms?
- What kinds of problems can be solved using surface areas of rectangular and triangular prisms?
- How can I use formulas to determine the volumes of right rectangular prism?
- How can I compute the surface area of rectangular and triangular prisms?

### **MATERIALS**

- Copies of Student Pages of the task

### **TECHNOLOGY CONNECTIONS**

This site allows students to interactive alter the dimensions for rectangular prism. It can be used to demonstrate how the changes in the dimensions affect the surface area and volume.

<http://www.shodor.org/interactivate/activities/SurfaceAreaAndVolume/>

The isometric geoboard is well-suited to create three-dimensional (polyhedra) representations.

[http://nlvm.usu.edu/en/nav/frames\\_asid\\_129\\_g\\_3\\_t\\_3.html?open=activities&from=category\\_g\\_3\\_t\\_3.html](http://nlvm.usu.edu/en/nav/frames_asid_129_g_3_t_3.html?open=activities&from=category_g_3_t_3.html)

Use this interactive tool to create dynamic drawings on isometric dot paper. Draw figures using edges, faces, or cubes. You can shift, rotate, color, decompose, and view in 2-D or 3-D.

<http://illuminations.nctm.org/ActivityDetail.aspx?ID=125>

### **TEACHER NOTES**

In this task, students will examine stacks of paper – or programs – and describe what they notice. They will be asked to discuss what they wonder about or are curious about. They will generate questions, particularly mathematical questions, that COULD be asked about the stack(s) of programs. Their questions will be recorded on a class chart. Students will then use mathematics to answer their own questions. Students will be given information as they ask for it in order to solve the problem(s).

### **TASK DESCRIPTION**

This task is divided into three parts. The LAUNCH presents a scenario and asks students to make inquiries about pictures of stacks of paper or programs. They generate questions that might be asked about the pictures.

The EXPLORATION presents students with four situations they can use mathematics to solve. The Exploration is divided into three parts that progress through the geometry standards for sixth grade.

The REFLECTION has the students revisit their original questions and summarize their learning and experience with volume and surface area.

### **Packaging our Goods – Rectangular Prisms (Spotlight Task)**

**LAUNCH.** *Stacks of paper. BRAINSTORM? What questions might be answered about the stacks of paper?*

*Students generate lists of questions, individually, in small group, debrief as a class. What might we be exploring, finding out? How could we begin to find answers?*





**EXPLORE** *Student work time*

Part 1

Quality Track printing company is filling an order of graduation programs for 11 high schools in the district. On average, there are 200 programs printed, packaged in stacks that are 50 cm high. What is the volume of the box needed to package these programs for shipping to schools?

*Have students identify what information is needed in order to fill the order?*

*The programs measure 10 cm by 17 cm by 2 cm.*

How many programs are packaged in stacks that are 50 cm high? How could the company determine the number of programs in any stack, of any height?

The company will seal wrap and package the programs. If 200 programs are packaged per box, how many stacks of programs will be packaged in one box?

Compute the dimensions of the box that Quality Track printing should use to package these orders with no leftover space. The length of the box must not exceed 44 cm, and the width of the box must not exceed 34 cm. Explain your rationale for choosing these dimensions for your box.

Part 2

Quality Track printing wants to increase one of the dimensions for the box by  $1\frac{1}{2}$  cm to form space that would prevent the programs from being damaged.

Draw and label a net for this box (not to scale), giving the largest dimensions for this box. What is its volume?

Part 3

The company has decided to place a decorative label on the lateral faces of the box. How much decorative paper is needed to cover the faces of the box? Explain how you know this is the correct amount of covering.

**REFLECT**

Which questions from your original brainstorm were answered in the task? Are there others that could now be answered from the information you have?

With a partner, explain what you know about volume and surface area.

If the programs and box were triangular shaped, what steps would you take to find the surface area of the prism?

## **Packaging our Goods – Rectangular Prisms (Spotlight Task)**

**LAUNCH.** What questions might be answered about the stacks of paper?



### **EXPLORE.**

#### **Part 1**

Quality Track printing company is filling an order of graduation programs for 11 high schools in the district. On average, there are 200 programs printed, packaged in stacks that are 50 cm high. What is the volume of the box needed to package these programs for shipping to schools?

How many programs are packaged in stacks that are 50 cm high? How could the company determine the number of programs in any stack, of any height?

The company will seal wrap and package the programs. If 200 programs are packaged per box, how many stacks of programs will be packaged in one box?

Compute the dimensions of the box that Quality Track printing should use to package these orders with no leftover space. The length of the box must not exceed 44 cm, and the width of the box must not exceed 34 cm. Explain your rationale for choosing these dimensions for your box.

Part 2

Quality Track printing wants to increase one of the dimensions for the box by  $1\frac{1}{2}$  cm to form space that would prevent the programs from being damaged.

Draw and label a net for this box (not to scale), giving the largest dimensions for this box. What is its volume?

Part 3

The company has decided to place a decorative label on the lateral faces of the box. How much decorative paper is needed to cover the faces of the box? Explain how you know this is the correct amount of covering.

**REFLECT**

Which questions from your original brainstorm were answered in the task? Are there others that could now be answered from the information you have?

With a partner, explain what you know about volume and surface area.

If the programs and box were triangular shaped, what steps would you take to find the surface area of the prism?

## **Painting the Barn (Spotlight Task)**

[Back to Task Table](#)

Task adapted from [www.illustrativemathematics.org](http://www.illustrativemathematics.org)

*In this inquiry-based task, students will reason about surface area to solve a real-world problem.*

### **STANDARDS FOR MATHEMATICAL CONTENT**

**MGSE6.G.4.** Represent three-dimensional figures using nets made up of rectangles and triangles, and use the nets to find the surface area of these figures. Apply these techniques in the context of solving real-world and mathematical problems.

### **STANDARDS FOR MATHEMATICAL PRACTICE**

- 1. Make sense of problems and persevere in solving them.** Given rectangular prisms, rectangular pyramids, triangular prisms, and triangular pyramids students will find surface area using nets.
- 2. Reason abstractly and quantitatively** – Students will use and draw nets for prisms when given the figure. Students will be able to see and justify the reasoning for decomposing and composing triangles and rectangles to solve for surface area. Students will use the relationships between two-dimensional and three-dimensional shapes to understand surface area.
- 3. Construct viable arguments and critique the reasoning of others.** Students will justify how they found surface area. Students will review solutions and justify (verbally and written) why the solutions are reasonable.
- 4. Model with mathematics.** Students will sketch nets for three-dimensional shapes.
- 6. Attend to precision.** Students will attend to precision as they use the language of mathematics in their mathematical arguments and discussions.
- 7. Look for and make use of structure.** Students will understand the relationship between the structure of a three-dimensional shape and the net and the surface area.

### **ESSENTIAL QUESTIONS**

- How can you model finding surface area rectangular and triangular pyramids?

### **MATERIALS**

- Images for the task (below)

### **TIME NEEDED**

- 2 class periods

### **TEACHER NOTES**

In this task, students will be presented with two images. They will then be asked to discuss what they wonder or are curious about. These questions will be recorded on a class chart or on the board. Students will then use mathematics to answer their own questions. Students will be given information to solve the problem based on need. When they realize they don't have the information they need, and ask for it, it will be given to them. Teachers may decide to make this

task more open by allowing students to research answers to some of the questions they ask (such as how much does the paint cost per gallon).

### **Task Description**

*More information along with guidelines for 3-Act Tasks may be found in the Comprehensive Course Guide.*

#### **ACT 1:**

Show the following pictures, one at a time for about 20 seconds each, then ask students what they wonder. Write these ideas on the board or on chart paper.





**Possible “wonders” students may ask:**

How long will it take to paint the barn?

How much should the painter charge to paint the barn?

**Suggested question: How much paint will it take to paint that barn when it is finished?  
How much will the paint cost?**

Ask students to make an estimate for how much paint it will take to paint the barn when it is finished. Have them make two more estimates – one they know is too low and one they know is too high. Have them place all three estimates on the empty number line on the student recording sheet.

**ACT 2:**

As students begin to think about how to answer the question, more questions will arise. As students ask these questions, provide the answers as needed.

**Student Question: How large is the area we need to paint?**

**Teacher Response: Look at this:**

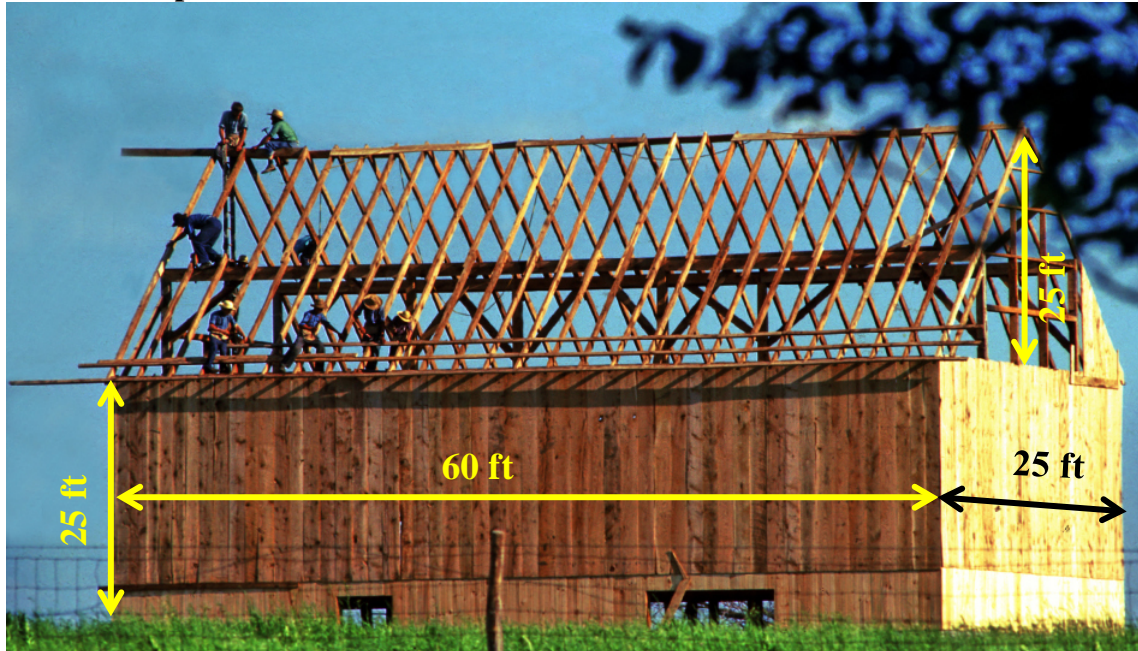

**Student: How much does the paint cost?**

**Teacher Response: Look at this:**

- [http://www.lowes.com/Paint/Paint-Primer/Exterior-Paint/\\_/N-1z0yax1/pl?Ns=p\\_product\\_qty\\_sales\\_dollar|1#!&N%5B%5D=1z0yax1&N%5B%5D=1z10vsk](http://www.lowes.com/Paint/Paint-Primer/Exterior-Paint/_/N-1z0yax1/pl?Ns=p_product_qty_sales_dollar|1#!&N%5B%5D=1z0yax1&N%5B%5D=1z10vsk)
- <http://www.homedepot.com/b/Paint-Exterior-Paint-Stain-Waterproofing-Barn-Fence-Paint/N-5yc1vZc6om>

Or provide students with time to research barn paint prices on their own.

Or give them some prices:

Behr Red Exterior Barn Paint \$14.98/gal.

Behr Red Exterior Barn Paint \$67.00/5gal.



### **ACT 3**

Students will compare and share solution strategies and construct viable arguments and critique other students' reasoning.

- Reveal the answer. Discuss the theoretical math versus the practical outcome.
- How appropriate was your initial estimate?
- Share student solution paths. Start with most common strategy.
- Revisit any initial student questions that weren't answered.

### **ACT 4**

#### **Extension:**

For students in need of an extension to this task, allow them to create a bid for the job of the painting of the barn. The lowest bid is awarded the job, but the bid must allow the company to make a profit after paying for the materials (paint, brushes, equipment and wages for the workers). Have teams of students research costs and write a bid explaining how they arrived at their bid.

#### **Intervention:**

For students requiring interventions, dimensions can be adjusted to friendlier numbers based on strategies students may be learning. Also, teachers should ask questions helping students through their productive struggles based on their own understandings.

Task Title: \_\_\_\_\_

Name: \_\_\_\_\_  
*Adapted from Andrew Stadel*

## ACT 1

What did/do you notice?

What questions come to your mind?

**Main Question:** \_\_\_\_\_

Estimate the result of the main question? Explain?

*Place an estimate that is too high and too low on the number line*

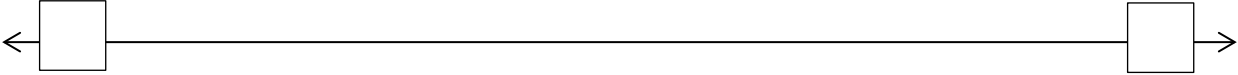

Low estimate                      Place an "x" where your estimate belongs                      High estimate

## ACT 2

What information would you like to know or do you need to solve the MAIN question?

Record the given information (measurements, materials, etc...)

If possible, give a better estimate using this information: \_\_\_\_\_

**Act 2 (con't)**

Use this area for your work, tables, calculations, sketches, and final solution.

## ACT 3

What was the result?

Which Standards for Mathematical Practice did you use?	
<input type="checkbox"/> Make sense of problems & persevere in solving them	<input type="checkbox"/> Use appropriate tools strategically.
<input type="checkbox"/> Reason abstractly & quantitatively	<input type="checkbox"/> Attend to precision.
<input type="checkbox"/> Construct viable arguments & critique the reasoning of others.	<input type="checkbox"/> Look for and make use of structure.
<input type="checkbox"/> Model with mathematics.	<input type="checkbox"/> Look for and express regularity in repeated reasoning.

## **Designing Candy Cartons (Formative Assessment Lesson)**

[Back to Task Table](#)

Source: *Formative Assessment Lesson Materials from Mathematics Assessment Project*

<http://map.mathshell.org/materials/download.php?fileid=1364>

### **TASK COMMENTS**

Tasks and lessons from the Mathematics Assessment Project are specifically designed to help teachers effectively formatively assess their students. The way the tasks and lessons are designed gives the teacher a clear understanding of what the students are able to do and not do. Within the lesson, teachers will find suggestions and question prompts that will help guide students towards understanding. For more information access the MAP website:

<http://www.map.mathshell.org/materials/background.php?subpage=formative>

The task, *Designing: Candy Cartons*, is a Formative Assessment Lesson (FAL) that can be found at the

website: <http://map.mathshell.org/materials/lessons.php?taskid=488&subpage=problem>

The FAL document provides a clear lesson design, from the opening of the lesson to the closing of the lesson.

The PDF version of the task can be found at the link below:

<http://map.mathshell.org/materials/download.php?fileid=1364>

### **STANDARDS FOR MATHEMATICAL CONTENT**

**Solve real-world and mathematical problems involving area, surface area, and volume.**

**MGSE6.G.1 Find area of right triangles, other triangles, quadrilaterals, and polygons by composing into rectangles or decomposing into triangles and other shapes; apply these techniques in the context of solving real-world and mathematical problems.**

**MGSE6.G.2. Find the volume of a right rectangular prism with fractional edge lengths by packing it with unit cubes of the appropriate unit fraction edge lengths ( $\frac{1}{2}$  u), and show that the volume is the same as would be found by multiplying the edge lengths of the prism. Apply the formulas  $V = (\text{length}) \times (\text{width}) \times (\text{height})$  and  $V = (\text{area of base}) \times (\text{height})$  to find volumes of right rectangular prisms with fractional edge lengths in the context of solving real-world and mathematical problems.**

**MGSE6.G.4** Represent three-dimensional figures using nets made up of rectangles and triangles, and use the nets to find the surface area of these figures. Apply these techniques in the context of solving real-world and mathematical problems.

### **STANDARDS FOR MATHEMATICAL PRACTICE**

This lesson uses all of the practices with emphasis on: 1, 3, 4

## **Candle Box (Short Cycle Task)**

[Back to Task Table](#)

Source: *Balanced Assessment Materials from Mathematics Assessment Project*

<http://www.map.mathshell.org/materials/download.php?fileid=1145>

### **TASK COMMENTS:**

Tasks and lessons from the Mathematics Assessment Project are specifically designed to help teachers effectively formatively assess their students. The way the tasks and lessons are designed gives the teacher a clear understanding of what the students are able to do and not do. Within the lesson, teachers will find suggestions and question prompts that will help guide students towards understanding. For more information access the MAP website: <http://www.map.mathshell.org/materials/background.php?subpage=summative>

The task, *Candle Box*, is a Mathematics Assessment Project Assessment Task that can be found at the website: <http://www.map.mathshell.org/materials/tasks.php?taskid=385&subpage=expert>

The PDF version of the task can be found at the link below:

<http://www.map.mathshell.org/materials/download.php?fileid=1145>

The scoring rubric can be found at the following link:

<http://www.map.mathshell.org/materials/download.php?fileid=1146>

### **STANDARDS FOR MATHEMATICAL CONTENT IN THIS TASK:**

**Solve real-world and mathematical problems involving area, surface area, and volume.**

**MGSE6.G.1 Find area of right triangles, other triangles, quadrilaterals, and polygons by composing into rectangles or decomposing into triangles and other shapes; apply these techniques in the context of solving real-world and mathematical problems.**

**MGSE6.G.2. Find the volume of a right rectangular prism with fractional edge lengths by packing it with unit cubes of the appropriate unit fraction edge lengths ( $\frac{1}{2}$  u), and show that the volume is the same as would be found by multiplying the edge lengths of the prism. Apply the formulas  $V = (\text{length}) \times (\text{width}) \times (\text{height})$  and  $V = (\text{area of base}) \times (\text{height})$  to find volumes of right rectangular prisms with fractional edge lengths in the context of solving real-world and mathematical problems.**

**MGSE6.G.4.** Represent three-dimensional figures using nets made up of rectangles and triangles, and use the nets to find the surface area of these figures. Apply these techniques in the context of solving real-world and mathematical problems.

### **Standards for Mathematical Practice**

This task uses all of the practices with emphasis on: 1, 2, 3 ,4, 5, 6, 7 & 8

## **Smoothie Box (Short Cycle Task)**

[Back to Task Table](#)

Source: *Balanced Assessment Materials from Mathematics Assessment Project*

<http://www.map.mathshell.org/materials/download.php?fileid=1166>

### **TASK COMMENTS:**

Tasks and lessons from the Mathematics Assessment Project are specifically designed to help teachers effectively formatively assess their students. The way the tasks and lessons are designed gives the teacher a clear understanding of what the students are able to do and not do. Within the lesson, teachers will find suggestions and question prompts that will help guide students towards understanding. For more information access the MAP website:

<http://www.map.mathshell.org/materials/background.php?subpage=summative>

The task, *Smoothie Box*, is a Mathematics Assessment Project Assessment Task that can be found at the website:

<http://www.map.mathshell.org/materials/tasks.php?taskid=392&subpage=expert>

The PDF version of the task can be found at the link below:

<http://www.map.mathshell.org/materials/download.php?fileid=1166>

The scoring rubric can be found at the following link:

<http://www.map.mathshell.org/materials/download.php?fileid=1167>

### **STANDARDS FOR MATHEMATICAL CONTENT IN THIS TASK:**

**Solve real-world and mathematical problems involving area, surface area, and volume.**

**MGSE6.G.1 Find area of right triangles, other triangles, quadrilaterals, and polygons by composing into rectangles or decomposing into triangles and other shapes; apply these techniques in the context of solving real-world and mathematical problems.**

**MGSE6.G.2. Find the volume of a right rectangular prism with fractional edge lengths by packing it with unit cubes of the appropriate unit fraction edge lengths ( $\frac{1}{2}$  u), and show that the volume is the same as would be found by multiplying the edge lengths of the prism. Apply the formulas  $V = (\text{length}) \times (\text{width}) \times (\text{height})$  and  $V = (\text{area of base}) \times (\text{height})$  to find volumes of right rectangular prisms with fractional edge lengths in the context of solving real-world and mathematical problems.**

**MGSE6.G.4.** Represent three-dimensional figures using nets made up of rectangles and triangles, and use the nets to find the surface area of these figures. Apply these techniques in the context of solving real-world and mathematical problems.

### **Standards for Mathematical Practice**

This task uses all of the practices with emphasis on: 1, 2, 3, 4, 5, 6, 7 & 8

## **Boxing Bracelets**

[Back to Task Table](#)

*In this task, students will solve a problem involving volume and surface area of right rectangular prisms.*

### **STANDARDS FOR MATHEMATICAL CONTENT**

**MGSE6.G.2. Find the volume of a right rectangular prism with fractional edge lengths by packing it with unit cubes of the appropriate unit fraction edge lengths ( $\frac{1}{2}$  u), and show that the volume is the same as would be found by multiplying the edge lengths of the prism. Apply the formulas  $V = (\text{length}) \times (\text{width}) \times (\text{height})$  and  $V = (\text{area of base}) \times (\text{height})$  to find volumes of right rectangular prisms with fractional edge lengths in the context of solving real-world and mathematical problems.**

**MGSE6.G.4.** Represent three-dimensional figures using nets made up of rectangles and triangles, and use the nets to find the surface area of these figures. Apply these techniques in the context of solving real-world and mathematical problems.

### **STANDARDS FOR MATHEMATICAL PRACTICE**

- 1. Make sense of problems and persevere in solving them.** Given a right rectangular prism, students will solve for the volume and surface area. Students will find surface area of triangular prism
- 2. Reason abstractly and quantitatively** – Students will use their understanding of volume to create the size of a box to ship a certain number of programs. Students will use the understanding of surface area to solve problems.
- 3. Construct viable arguments and critique the reasoning of others.** Students will be able to review solutions to justify (verbally and written) why the solutions are reasonable.
- 4. Model with mathematics.** Use will sketch the rectangular prisms.
- 6. Attend to precision.** Students will use appropriate measurement units (square units vs. cubic units) and correct terminology to justify reasonable solutions.
- 7. Look for and make use of structure.** Students will understand the relationship between the structure of a three-dimensional shape and its volume formula and surface area.
- 8. Look for and express regularity in repeated reasoning.** Students will explain why formula or process is used to solve given problems. Students use properties of figures and properties of operations to connect formulas to surface area and volume.

### **ESSENTIAL QUESTIONS**

- How can I use manipulatives and nets to help compute the surface areas of rectangular prisms?
- How can I compute the surface area of rectangular prisms?
- What kinds of problems can be solved using surface areas of rectangular prisms?
- How can I use formulas to determine the volumes of right rectangular prism?

**TASK COMMENTS**

This task can be used as a learning task. Students should be given opportunities to revise their work based on teacher feedback, peer feedback, and metacognition which includes self-assessment and reflection.

**Boxing Bracelets**



You are the owner of a prestigious jewelry store that sells popular bracelets. They are packaged in boxes that measure 8.3 centimeters by 11 centimeters by 2.5 centimeters.



**Part I.**

1. Sketch a drawing of the box and label its dimensions.

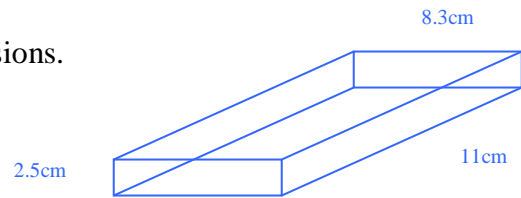

2. Estimate the volume of the bracelet box.

*(8)(3)(10) or about 240 cm<sup>3</sup>*

3. Find the volume of the bracelet box. Be sure to show all of your work.

*V = lwh when V=volume, l=length, w=width, and h=height.*

*V = (11)(8.3)(2.5)*

*V = 228.25cm<sup>3</sup>*

**Part II.**

Suppose the company that makes your boxes is out of the ones that you usually purchase. They have offered to send you another size box for the same cost. The three different boxes that you may choose from have two of the dimensions the same as your regular box, but increase one of the dimensions by exactly 1 centimeter.

1. List the dimensions of three boxes they are offering to send.

Box 1	Box 2	Box 3
<i>(2.5)(8.3)(12)</i>	<i>(2.5)(9.3)(11)</i>	<i>(3.5)(8.3)(11)</i>

2. Make a prediction of which box you would order if you wanted the largest possible increase in volume.

A. Explain with details how you could be certain of which dimension you should increase.



*Because we want the largest product of three numbers, we want to increase the smallest one. Therefore, the box with the largest possible increase should be the one with the dimensions of 3.5 cm, 8.3 cm, and 11 cm.*

*Explain with details how you could be certain of which dimension you should increase. Although the logic seems certain, testing the three possible new volumes by substituting the new values would prove the logical reasoning.*

B. Test your prediction.

*Increasing 2.5cm to 3.5cm:*  $V=(3.5)(8.3)(11)$   
 $=319.55\text{cm}^3$

*Increasing 8.31cm to 9.31cm:*  $V=(2.5)(9.3)(11)$   
 $=255.75\text{cm}^3$

*Increasing 11cm to 12 cm:*  $V=(2.5)(8.3)(12)$   
 $=249\text{cm}^3$

C. Was your prediction correct? Why or why not?

*The prediction was correct because the additional volume is formed by adding a very thin (1cm thick) rectangular prism to one side of the original box. The side with the largest area is the one that has an area determined by multiplying the two largest numbers.*

3. Make a **sketch** of the new box and label its dimensions and find the **volume** of the new box. Show all of your work.

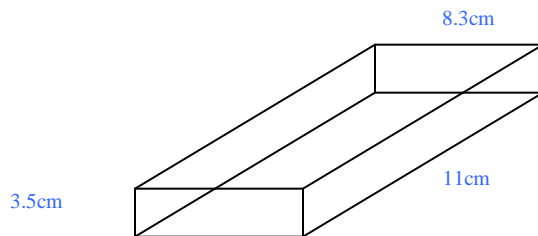

$$V=(2.5)(8.3)(11)$$
$$=228.25\text{cm}^3$$

4. What is the difference of the volume of the original box and the volume of the new box?

Solution

$$\begin{array}{r} 319.55 \\ - 228.25 \\ \hline 91.30\text{cm}^3 \end{array}$$

**Part III.**

Some of your customers frequently like to have their bracelets gift wrapped. To determine the price for wrapping the new boxes, you wish to compare the surface area of the original box to the surface area of the box with the largest volume. (*Note – we are thinking about the net so we are ignoring the fact that when you actually wrap a gift some paper is overlapped.*)

1. Sketch a drawing of the nets of the two boxes (new and old) and label the dimensions.

2. Find the actual surface area for each box.

*Original:*  $SA = 91.3 + 91.3 + 20.75 + 20.75 + 27.5 + 27.5$   
 $= 279.1 \text{ cm}^2$

*New*  $SA = 91.3 + 91.3 + 29.05 + 29.05 + 38.5 + 38.5$   
 $= 317.7 \text{ cm}^2$

3. If you charge \$2.00 to gift wrap the original box, how much should you charge to gift wrap the new box? Justify your answer.

Solution

*Because the percent of increase in the surface area is a little less than 15%, the new price should reflect about a 15% increase. Since 15% of \$2.00 is \$0.30, the price for gift wrapping the new box should be \$2.30.*

## Boxing Bracelets



You are the owner of a prestigious jewelry store that sells popular bracelets. They are packaged in boxes that measure 8.3 centimeters by 11 centimeters by 2.5 centimeters.



### Part I.

1. Sketch a drawing of the box and label its dimensions.
2. Estimate the volume of the bracelet box.
3. Find the volume of the bracelet box. Be sure to show all of your work.

### Part II.

Suppose the company that makes your boxes is out of the ones that you usually purchase. They have offered to send you another size box for the same cost. The three different boxes that you may choose from have two of the dimensions the same as your regular box, but increase one of the dimensions by exactly 1 centimeter.

1. List the dimensions of three boxes they are offering to send.

Box 1	Box 2	Box 3

2. Make a prediction of which box you would order if you wanted the largest possible increase in volume.

A. Explain with details how you could be certain of which dimension you should increase.

B. Test your prediction.

C. Was your prediction correct? Why or why not?

3. Make a **sketch** of the new box and label its dimensions and find the **volume** of the new box. Show all of your work.

Volume \_\_\_\_\_

4. What is the difference of the volume of the original box and the volume of the new box?



## **The File Cabinet (Spotlight Task)**

[Back to Task Table](#)

Taken from <http://www.estimated180.com/filecabinet.html>

*In this inquiry-based task, students will reason about surface areas by estimating how many sticky-notes it will take to completely cover the surfaces of a file cabinet.*

### **STANDARDS FOR MATHEMATICAL CONTENT**

**MGSE6.G.4.** Represent three-dimensional figures using nets made up of rectangles and triangles, and use the nets to find the surface area of these figures. Apply these techniques in the context of solving real-world and mathematical problems.

### **STANDARDS FOR MATHEMATICAL PRACTICE**

- 1. Make sense of problems and persevere in solving them.** Students must make sense of the problem by identifying what information they need to solve it.
- 2. Reason abstractly and quantitatively.** Students were asked to make an estimate (high and low).
- 3. Construct viable arguments and critique the reasoning of others.** After writing down their own question, students discussed their question with tablemates, creating the opportunity to construct the argument of why they chose their question, as well as critiquing the questions that others came up with.
- 4. Model with mathematics.** Once the given information was communicated, the students used that information to develop a mathematical model.
- 5. Use appropriate tools strategically.** In the “debrief”, the teacher discussed the different use of tools. By doing this, students are provided with more tools in their toolbox for future problem solving.
- 6. Attend to precision.** Students correctly vocabulary (row, columns, units of measure) to ensure that they are communicating precisely.
- 7. Look for and make use of structure.** The students had to develop an understanding of the physical structure in order to develop a mathematical model that had a numerical structure of its own. The student had to make the connection between the physical structure and the numerical structure of the mathematical model.

### **ESSENTIAL QUESTIONS**

- How can I use manipulatives and nets to help compute the surface area of rectangular prisms?
- What kind of problems can be solved using surface areas?

### **MATERIALS REQUIRED**

- Sticky notes
- Act 1 Video: <http://vimeo.com/40917688>
- Act 2: dimension of file cabinet and sticky notes (pictures included)
- Act 3 Video: <http://vimeo.com/41227350>

### **TIME NEEDED**

- 1 day

### **TEACHER NOTES**

In this task, students will watch the video, then tell what they noticed. They will then be asked to discuss what they wonder or are curious about. These questions will be recorded on a class chart or on the board. Students will then use mathematics to answer their own questions. Students will be given information to solve the problem based on need. When they realize they don't have the information they need, and ask for it, it will be given to them. In this task, students will estimate the surface area of a file cabinet using sticky notes as their unit.

### **Task Description**

The following 3-Act Task can be found at: <http://www.estimated180.com/filecabinet.html>

*More information along with guidelines for 3-Act Tasks may be found in the Comprehensive Course Guide.*

### **ACT 1:**

Watch the video: <http://vimeo.com/40917688>

Students are asked what they noticed in the video. Students record what they noticed or wondered on the recording sheet. Students are asked to discuss and share what they wondered (or are curious about) as related to what they saw in the video.

Important Note: Although the MAIN QUESTION of this lesson is ***“How many sticky notes will cover the file cabinet”*** it is important for the teacher to not ignore student generated questions and try to answer as many of them as possible (before, during, and after the lesson as a follow up).

Main Question: ***How many sticky notes will cover the file cabinet?***

Write down an estimate you know if too high? Too low?

**ACT 2:**

Students will realize that they do not have enough information to complete the problem. Release the following information to students **ONLY AFTER** they have identified what information they need.

Dimension of sticky notes	Dimensions of the file cabinet
<p style="text-align: center;"><b>Sticky note</b></p> <p style="text-align: center;"><b>Dimensions: 3" x 3"</b></p>	<p style="text-align: center;"><b>Height: 72 inches</b></p> <p style="text-align: center;"><b>Width: 36 inches</b></p> <p style="text-align: center;"><b>Depth: 18 inches</b></p>

\*\*\*do not give all of the dimension of the file cabinet to students unless they are asked for\*\*\*

Students may work individually for 5-10 minutes to come up with a plan, test ideas, and problem-solve. After individual time, students may work in groups (3-4 students) to collaborate and solve this task together.

**ACT 3**

The reveal: <http://vimeo.com/41227350>

Students will compare and share solution strategies.

- Reveal the answer. Discuss the theoretical math versus the practical outcome.
- How appropriate was your initial estimate?
- Share student solution paths. Start with most common strategy.
- Revisit any initial student questions that weren't answered.

**Formative Assessment Questions**

- How did your understanding of area help you model the number of sticky notes it would take to cover the file cabinet?
- What models did you create?
- What organizational strategies did you use?



Task Title: \_\_\_\_\_

Name: \_\_\_\_\_

*Adapted from Andrew Stadel*

## ACT 1

What did/do you notice?

What questions come to your mind?

**Main Question:** \_\_\_\_\_

Estimate the result of the main question? Explain?

*Place an estimate that is too high and too low on the number line*

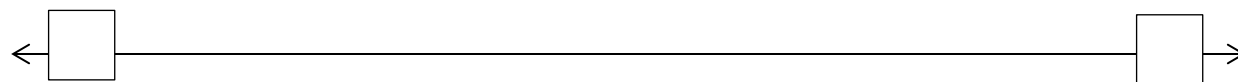

Low estimate

*Place an "x" where your estimate belongs*

High estimate

## ACT 2

What information would you like to know or do you need to solve the MAIN question?

Record the given information (measurements, materials, etc...)

If possible, give a better estimate using this information: \_\_\_\_\_

**Act 2 (con't)**

Use this area for your work, tables, calculations, sketches, and final solution.

## ACT 3

What was the result?

Which Standards for Mathematical Practice did you use?	
<input type="checkbox"/> Make sense of problems & persevere in solving them	<input type="checkbox"/> Use appropriate tools strategically.
<input type="checkbox"/> Reason abstractly & quantitatively	<input type="checkbox"/> Attend to precision.
<input type="checkbox"/> Construct viable arguments & critique the reasoning of others.	<input type="checkbox"/> Look for and make use of structure.
<input type="checkbox"/> Model with mathematics.	<input type="checkbox"/> Look for and express regularity in repeated reasoning.

## **Culminating Task: Fish Tank Foam Packing Design (STEM)**

[Back to Task Table](#)

*In this task, students will design the foam packaging for Fish Tank Experts. The students will determine dimensions, describe the effects of the fractional edge lengths, and compute the minimum amount of space needed to package a 15-gallon tank.*

### **STANDARDS FOR MATHEMATICAL CONTENT**

**MGSE6.G.1 Find area of right triangles, other triangles, quadrilaterals, and polygons by composing into rectangles or decomposing into triangles and other shapes; apply these techniques in the context of solving real-world and mathematical problems.**

**MGSE6.G.2. Find the volume of a right rectangular prism with fractional edge lengths by packing it with unit cubes of the appropriate unit fraction edge lengths ( $\frac{1}{2}$  u), and show that the volume is the same as would be found by multiplying the edge lengths of the prism. Apply the formulas  $V = (\text{length}) \times (\text{width}) \times (\text{height})$  and  $V = (\text{area of base}) \times (\text{height})$  to find volumes of right rectangular prisms with fractional edge lengths in the context of solving real-world and mathematical problems.**

**MGSE6.G.4.** Represent three-dimensional figures using nets made up of rectangles and triangles, and use the nets to find the surface area of these figures. Apply these techniques in the context of solving real-world and mathematical problems.

### **STANDARDS FOR MATHEMATICAL PRACTICE**

- 1. Make sense of problems and persevere in solving them.** Given a right rectangular prism a student will solve for the volume and surface area. Students will find surface area of triangular prism
- 2. Reason abstractly and quantitatively** – Students will use their understanding of volume to create the size of a box to ship a certain number of programs. Students will use the understanding of surface area to solve problems.
- 3. Construct viable arguments and critique the reasoning of others.** Students will be able to review solutions to justify (verbally and written) why the solutions are reasonable.
- 4. Model with mathematics.** Use will sketch the rectangular prisms.
- 6. Attend to precision.** Students will use appropriate measurement units (square units vs. cubic units) and correct terminology to justify reasonable solutions.
- 7. Look for and make use of structure.** Students will understand the relationship between the structure of a three-dimensional shape and its volume formula and surface area.
- 8. Look for and express regularity in repeated reasoning.** Students will explain why formula or process is used to solve given problems. Students use properties of figures and properties of operations to connect formulas to surface area and volume.

### **ESSENTIAL QUESTIONS**

- How can I use manipulatives and nets to help compute the surface areas of rectangular and triangular prisms?
- How can I use formulas to compute the surface area of rectangular and triangular prisms?

- What kinds of problems can be solved using surface areas of rectangular and triangular prisms?

### **DIFFERENTIATION**

This site allows students to interactive alter the dimensions for rectangular prism. It can be used to demonstrate how the changes in the dimensions affect the surface area and volume. <http://www.shodor.org/interactivate/activities/SurfaceAreaAndVolume/>

The isometric geoboard is well-suited to create three-dimensional (polyhedra) representations. [http://nlvm.usu.edu/en/nav/frames\\_asid\\_129\\_g\\_3\\_t\\_3.html?open=activities&form=category\\_g\\_3\\_t\\_3.html](http://nlvm.usu.edu/en/nav/frames_asid_129_g_3_t_3.html?open=activities&form=category_g_3_t_3.html)

Use this interactive tool to create dynamic drawings on isometric dot paper. Draw figures using edges, faces, or cubes. You can shift, rotate, color, decompose, and view in 2-D or 3-D. <http://illuminations.nctm.org/ActivityDetail.aspx?ID=125>

## **TASK: (STEM) FISH TANK FOAM PACKING DESIGN**



The STEM (Science, Technology, Engineering, and Math) Club has been asked to help the company, Fish Tank Experts. Lately, Fish Tank Experts have had to recall their 15-gallon fish tank equipment due to breakage during shipment. They have found that their equipment is breaking because the foam that encases the tank needs to be thicker and stronger.

The 15-gallon fish tank measures  $24 \times 12 \frac{1}{2} \times 12 \frac{3}{4}$  inches.

1. What is the volume of the fish tank? *Volume = 3825 inches<sup>3</sup>.*

To protect the fish tank a new foam packaging material has been designed that is  $\frac{1}{4}$  inch thick. The foam material will surround the fish tank on all sides. In other words, the fish tank will fit inside this foam packaging material. (The fish tank is a rectangular prism setting inside the foam packaging material that is a rectangular prism.)

2. What are the dimensions of the foam packaging material?  *$24 \frac{1}{2} \times 13 \times 13 \frac{1}{4}$  inches.*
3. What is the volume of the foam packaging?  
*Volume = 4,220  $\frac{1}{8}$  inches<sup>3</sup>.*
4. What is the difference in the volume of fish tank and foam packaging?  *$395 \frac{1}{8}$  inches<sup>3</sup>*

The company needs to for you to create labels for the outside of the box and for the fish tank. The dimensions of the box used to ship the fish task will be the same as the dimensions of the packing material in #2.

5. Sketch the net for the box used to ship the fish tank and the fish tank. Note – the fish tank is open at the top so it has no top in the net.

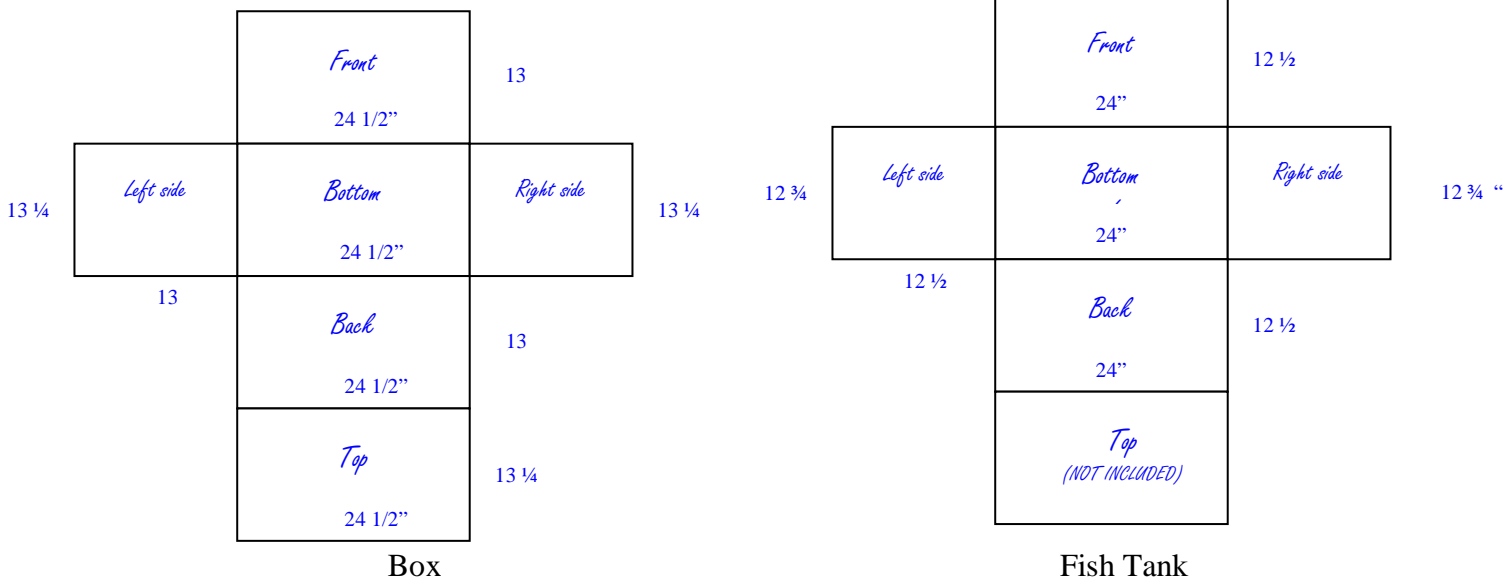

6. Using these nets find the surface area of each.

*Surface Area of Box*

*Front and Back*  $318 \frac{1}{2}$       *Sides*  $172 \frac{1}{4}$       *Top and Bottom*  $324 \frac{5}{8}$   
 $SA = \text{Back } 318 \frac{1}{2} + 318 \frac{1}{2} + 172 \frac{1}{4} + 172 \frac{1}{4} + 324 \frac{5}{8} + 324 \frac{5}{8} = 1630 \frac{3}{4}$   
*inches<sup>2</sup>*

*Surface Area of Fish Tank*

*Front and Back*  $300$       *Sides*  $159 \frac{3}{8}$       *Bottom*  $306$   
 $SA = 300 + 300 + 159 \frac{3}{8} + 306 = 1224 \frac{3}{4}$  *inches<sup>2</sup>*

7. The label for the box will only be on the lateral sides. What is the area of the label for the box?  
 $981.5 \text{ inches}^2$
8. The label for the fish tank will only be on the front. What is the area of the label for the fish tank?  
 $300 \text{ inches}^2$

The company wants you to design an irregular polygon that will fit on the label for the fish tank. They want you to be creative. Use rectangles, triangles, and special quadrilaterals to compose this design (an irregular polygon that fits on the front of the fish tank) Use graph paper.

9. Calculate the area of your design.

*Answers will vary*

10. Explain your design. What polygons were used? How did you calculate the area?

11. Color your design and describe your solution to the Fish Tank Experts.

Name \_\_\_\_\_ Date \_\_\_\_\_

**TASK: (STEM) FISH TANK FOAM PACKING DESIGN**



The STEM (Science, Technology, Engineering, and Math) Club has been asked to help the company, Fish Tank Experts. Lately, Fish Tank Experts have had to recall their 15-gallon fish tank equipment due to breakage during shipment. They have found that their equipment is breaking because the foam that encases the tank needs to be thicker and stronger.

The 15-gallon fish tank measures  $24 \times 12 \frac{1}{2} \times 12 \frac{3}{4}$  inches.

1. What is the volume of the fish tank?

To protect the fish tank a new foam packaging material has been designed that is  $\frac{1}{4}$  inch thick. The foam material will surround the fish tank on all sides. In other words, the fish tank will fit inside this foam packaging material. (The fish tank is a rectangular prism setting inside the foam packaging material that is a rectangular prism.)

2. What are the dimensions of the foam packaging material?
3. What is the volume of the foam packaging?
4. What is the difference in the volume of fish tank and foam packaging?



**Georgia Department of Education**  
Georgia Standards of Excellence Framework  
*GSE Grade 6 Mathematics • Unit 5*

The company needs to for you to create labels for the outside of the box and for the fish tank. The dimensions of the box used to ship the fish tank will be the same as the dimensions of the packing material in #2.

5. Sketch the net for the box used to ship the fish tank and the fish tank. Note – the fish tank is open at the top so it has no top in the net.

Box

Fish Tank

6. Using these nets find the surface area of each.

7. The label for the box will only be on the lateral sides. What is the area of the label for the box?

8. The label for the fish tank will only be on the front. What is the area of the label for the fish tank?

The company wants you to design an irregular polygon that will fit on the label for the fish tank. They want you to be creative. Use rectangles, triangles, and special quadrilaterals to compose this design (an irregular polygon that fits on the front of the fish tank. Use graph paper.

9. Calculate the area of your design.

10. Explain your design. What polygons were used? How did you calculate the area?

11. Color your design and describe the Fish Tank Experts.



**Georgia Department of Education**  
Georgia Standards of Excellence Framework  
*GSE Grade 6 Mathematics • Unit 5*

<http://www.openmiddle.com/rectangular-prism-surface-area-versus-volume/>  
<http://www.openmiddle.com/rectangular-prism-surface-area/>  
<http://www.shodor.org/interactivate/activities/SurfaceAreaAndVolume/>  
<http://illuminations.nctm.org/Activity.aspx?id=4182>